

**Repair of the Coupling Head implies Risk**

Changing the sealing ring in the coupling head is quickly managed. Afterwards, no further air will fizzle, leak out of the connection

However, using the wrong sealing element might lead to a sudden leakage which is bigger than before the repair took place. The driver will not recognize this while driving.

A pressure drop at the red coupling head, because of the leakage can result in partial braking of the trailer. This may lead to heated brakes, consequential damages and must be prevented.

A professional repair of WABCO coupling heads with product numbers 952 201 011 0 ... ~017 0 is done by using the repair kit 952 201 920 2. This kit offers two different sealing rings.

Please use the accurate sealing ring according to the design of the inner filter.

If the filter is two-part as shown on the left in figure 1, the more flat sealing ring is to be used. The one-piece filter design like on the right side of figure 1 defines the usage of the thick sealing ring.

Figure 2 describes the assembly sequence of the coupling head.

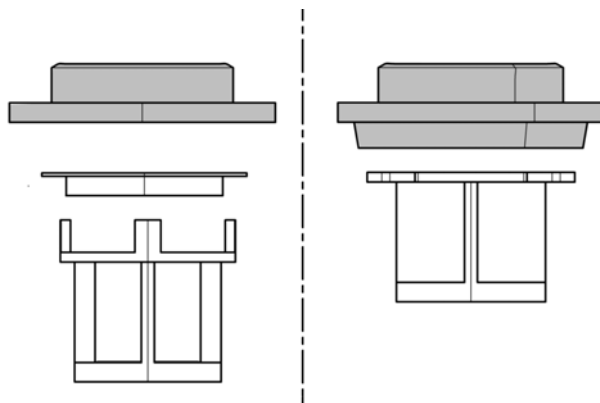

Figure 1

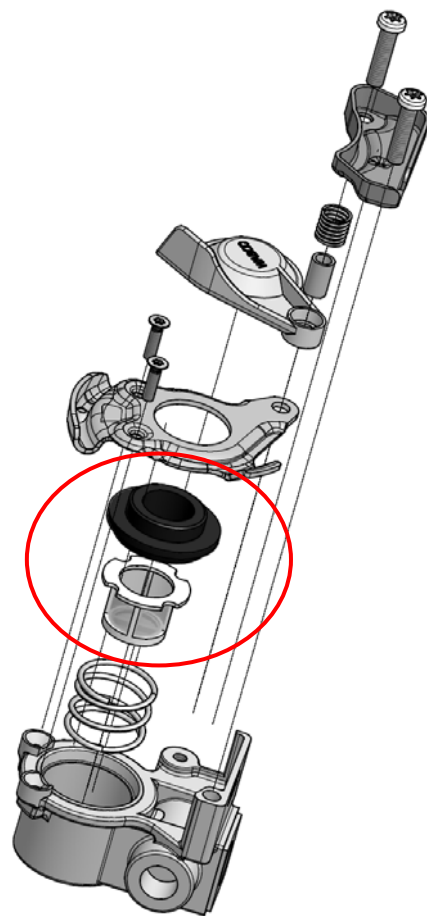

Figure 2