

Improved Double Diaphragm Spring Brake

As requested by customers, the design of the type 16/24 double diaphragm spring brake has been changed to reflect the compact design of the type 20/24.

This change produces the following **benefits** for you:

Extended application range

- Improvement of the spring design reduces the spring brake length by 12 mm. This makes the installation much easier, including applications for vehicles where conditions are cramped



Savings in cost due to a longer service life

- A more robust diaphragm / piston connection and optimised piston rod guiding, ensure improved functionality - especially where road conditions are poor.
- Extra seals stop any water penetration into the service brake component - even when the dust cap goes missing.

We would like to kindly remind you that these improvements come with a change in the product number:

16/24" existing	16/24" new
925 384 001 0	925 384 010 0



Below, you will find an overview of the most important double diaphragm spring brakes. These can be fitted on practically all trailers with disc brakes.

From now on we can also provide you with pipe extensions to ease spring brake installation where conditions are cramped.

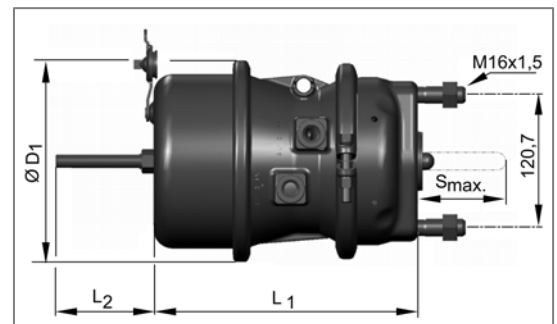

Type	S max [mm]	L1 [mm]	L2 [mm]	Ø D1 [mm]	Product number	Pipe extension
16/24"	57/57	229	89	184	925 384 010 0	925 384 050 2
20/24"	64/64	240,5	89	184	925 380 101 0	925 380 050 2

Do note that competitor appliances and predecessor products must be exchanged on an axle-by-axle basis.

Please direct any questions either to your personal WABCO contact or visit us under <http://www.wabco-auto.com>.