

**ADR- (GGVS-) Vehicles require ABS of category A or 1**

The quality of an ABS system is mainly defined by the number of control circuits. This way, e.g. a semitrailer with 2 sensors and one modulator (2S/1M) only has one control circuit, with which the modulation of the brake pressure is determined for the entire vehicle on the wheel with the greatest initial lock.

A vehicle with ABS of category A (trailer) or 1 (towing vehicle) on the other hand, has one control circuit for each side of the vehicle and is equipped with 2S/2M or on multi-axle vehicles with 4S/2M or 4S/3M. Only this way can an optimal braking distance be achieved on different road surfaces on each side of the vehicle (e.g. ice on the edge of the road, dry asphalt in the middle) to help prevent accidents.



**New specifications for ADR vehicles**

According to the "European Agreement concerning the International Carriage of Dangerous Goods by Road (ADR)", Part 8/9, vehicles that transport dangerous goods are required to have ABS of category 1 or A since the beginning of 2010.

In a purely practical sense, this means that an ADR semitrailer with 2S/1M will fail the next main inspection.

**Period of grace for Germany, France, Belgium, Latvia and the Czech Republic**

The Multilateral Agreement Number 214 put an agreement into effect that delays the above indicated specification for one year in 5 member states of the European Union. This makes it possible to operate vehicles with ABS category B up until 1.1.2011 in the indicated countries. However any traffic that crosses borders into other countries has to be equipped accordingly.

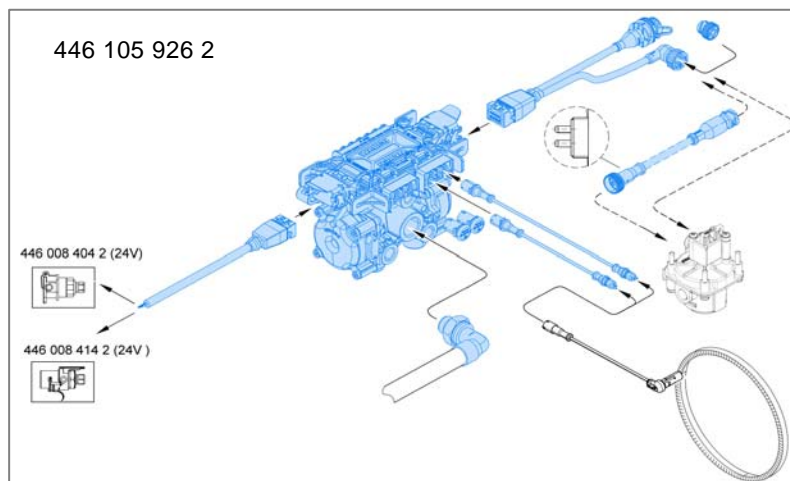

**What must be done?**

Check the installed system on your ADR vehicles. A system with at least two modulators must be installed, towing vehicles with at least 3 modulators.

Since WABCO has recommended category A as standard equipment in the past, vehicles with WABCO ABS or EBS will most likely suffice with the new ADR agreement. Category 1 was almost always installed in towing vehicles so

that there will probably be no requirement for action here either.

Should your towing vehicle require retrofitting, the VCS II retrofit package 446 105 926 2 (alternatively 446 108 923 2 for UK and Ireland) will bring the vehicle to the required status. However, the retrofit with trailer EBS E could also be a factor in realising additional functionality and increasing your vehicle utilisation value and trade-in value. Contact your WABCO Partner!