

Replacement of Vario C – Systems

The market information "Repairs to ABS Trailer Systems" from April last year has already introduced repair kits for the repair of older trailer vehicles with ABS systems of the Vario C or VCS type.

We have now developed a second, more economically priced, repair kit for Vario C systems. This repair kit can be used provided that the existing solenoid valves are in such good condition that they can be reused.

In the following sections we offer a comparative description the old solution and the new one.



Figure: Vario C

Repair Kit 446 105 926 2

The parts coloured blue are included in the repair kit.

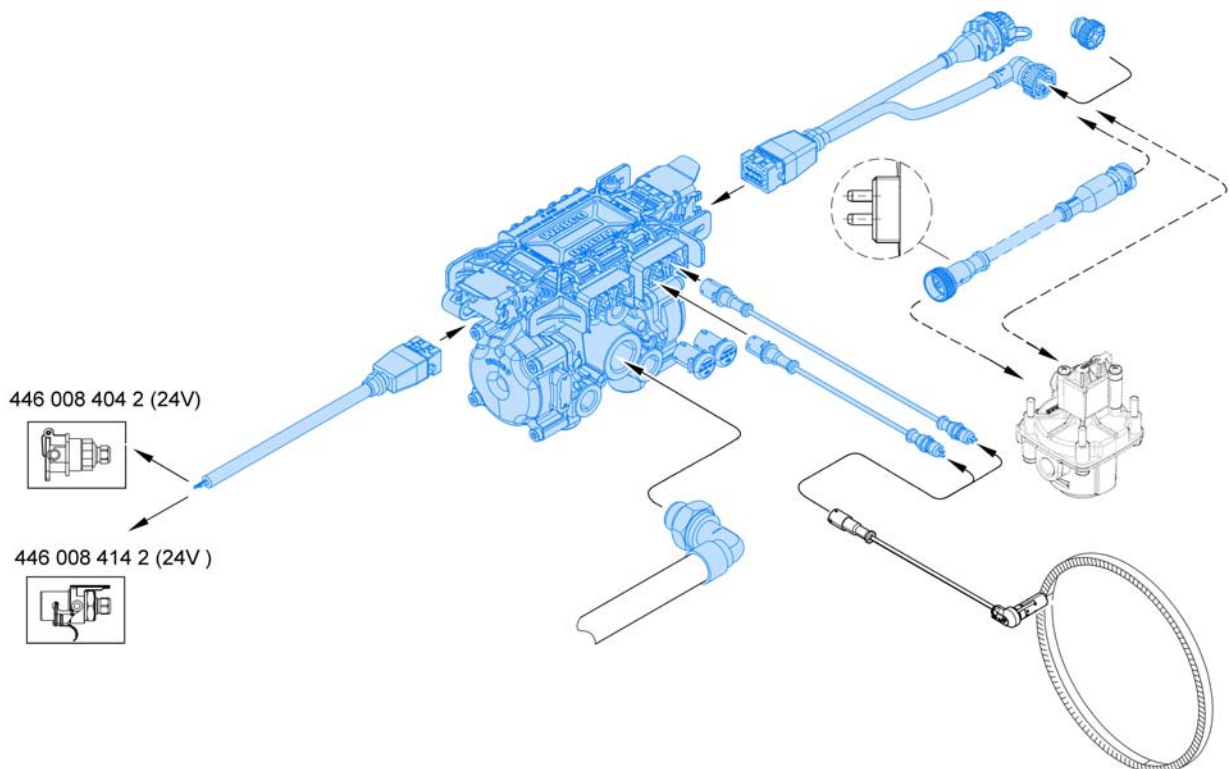

The repair kit 446 105 926 2 comes with a modern VCS II compact valve. A sensor extension cable and supply cable, to which the existing ABS connector is fitted, are provided for adaptation to a modern cabling system.

Installing a new compact unit means that the modulators are also renewed, a measure that especially makes sense where older vehicles are concerned. A further ABS relay valve can be connected for drawbar trailers (4S/3M systems). An adapter with connector is included in the kit. Provided the existing third modulator is in good condition, it can continue to be used.

Repair Kit 446 105 927 2

The parts coloured blue are included in the repair kit.

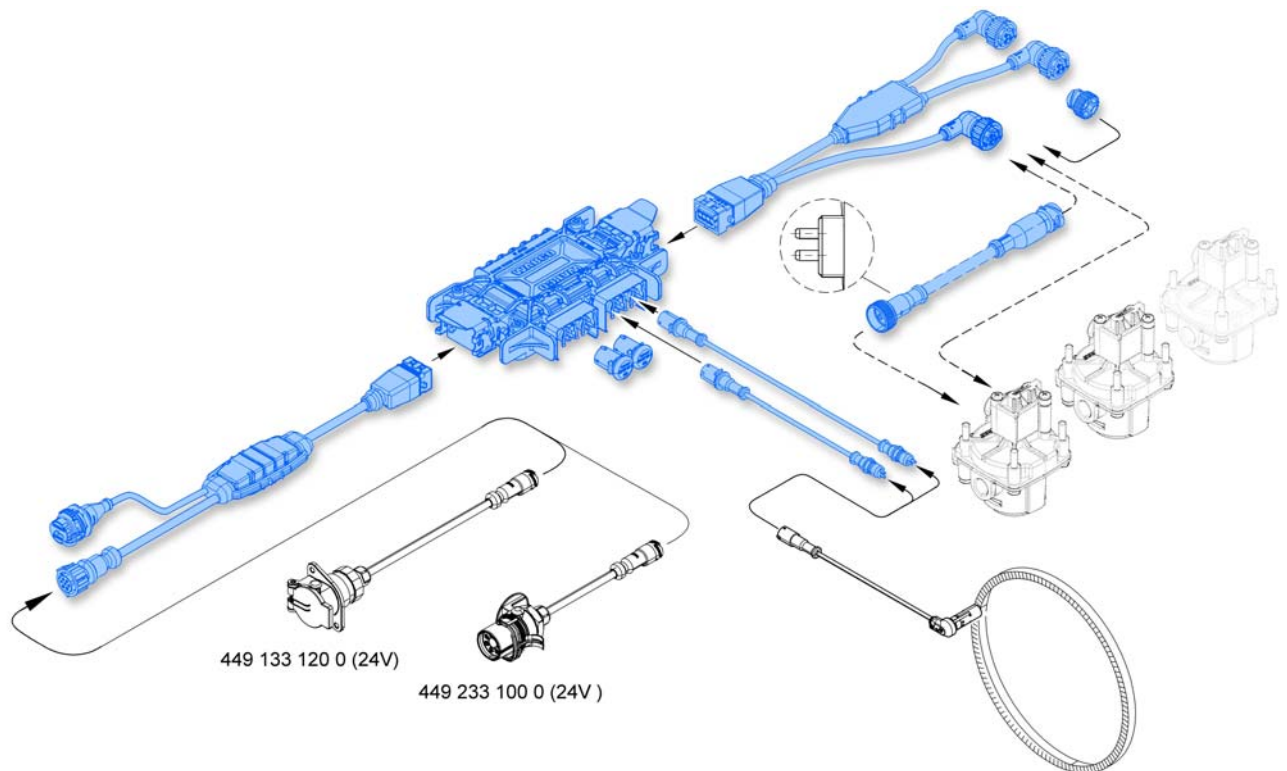

Only cables and the electronics are replaced in the case of repair kit 446 105 927 2. The solenoid valves with Kostal or bayonet connectors are now also reused, as are the sensors.

The use of a separate VCS II electronic system instead of the compact unit makes this solution more economical. Connecting a third modulator for drawbar trailers (4S/3M systems) is also possible in this case. All three solenoid valves must be of the same type: either solenoid control valves or ABS relay valves.

The supply cable shown in the illustration is not supplied with the repair kit. Please order the cable matching the respective vehicle type separately.

The new repair kit is available immediately.



Many countries require a new acceptance inspection once an ABS system has been replaced. Please contact the relevant local authority regarding this matter.

The required VCS II - certificate is available in INFORM at www.wabco-auto.com

Please speak to your WABCO partner about this new product.