

## WABCO replacement brakes without linings – save costs with safety

### Replacing the linings on just one side of an axle represents a safety risk!

Our experience shows that work is often carried out on one brake, while servicing the brake on the opposite side is often forgotten. This leads to an uneven braking effect and increased risk of accidents. Further repairs which are often more time-consuming can increase and these repair costs are considerably greater than a complete lining replacement on both sides of the axle.

### For these reasons WABCO supplies:

- Only sets of linings for both sides of an axle
- Brake lining sets that always include WABCO hold-down systems
- Replacement brakes (without linings)

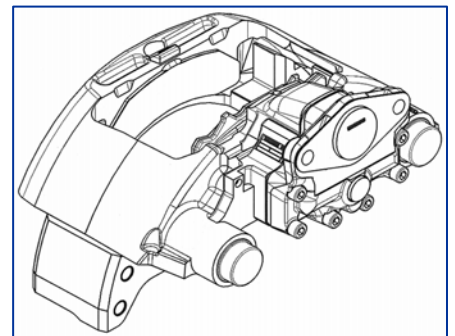

### Your benefit:

- Reducing costs for linings
- No added safety risk due to the linings on either side of the axle being worn unevenly.

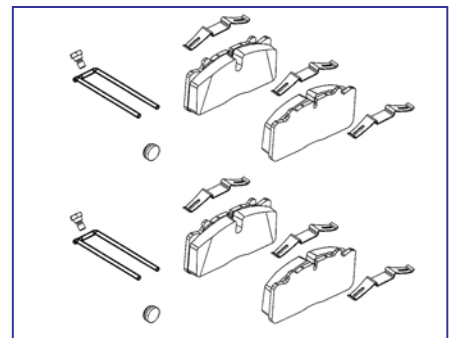

### The WABCO concept for replacements is therefore associated with:

- Improved safety
- Cost reduction.

In what situations do you need a replacement brake? When the old brake is defective and can no longer be used.

Does this also mean that all brake linings are worn and need to be replaced?

Definitely not!

In principle, reusing partially worn brake linings is OK.

However, it should be checked whether the residual lining thickness is equal. Before you continue using partially worn brake linings, the following points must be observed:

#### WARNING



Brake linings must **not** be reused if they exhibit one or more of the following properties:

- Visible fissures,
- Lining chipped, especially at the edges (> 3 mm),
- Excessive corrosion,
- Deformed back plate,
- Friction surface soiled with grease or oil,
- Hold-down springs, hold-down hoop, fastening screw damaged.

15.09.2007

WABCO repair kits are designed to include all safety-relevant parts required for the correct repair according to good professional practice, therefore minimising costs in advance by preventative maintenance.

We again point out that WABCO hold-down systems are designed for the service life of the brake linings and must also be replaced when the brake linings are renewed. Claims for defects and product liability claims will not be accepted if parts are used that have not been approved by WABCO.

**Layout and function of the WABCO hold-down systems in combination with the original brake linings are protected by patent (EP 0 694 707 B1) for the entire PAN series. Only WABCO and distribution partners authorised by WABCO are permitted to sell and distribute such components.**

All the spare parts we supply are of OEM quality that you have come to expect from WABCO.

If you have any questions, please get in touch with your WABCO contact person!

