

XD

Expert Diagnostics



WABCO

XD

Expert Diagnostics

User Manual

Edition 4

This publication is not subject to any update service.
You will find the latest version in INFORM
www.wabco-auto.com

© 2008 WABCO

WABCO

The right of amendment is reserved.

Version 1/09.2008(en)

815 010 111 3

Abbreviations

366d	366 days
4UP	4 updates
ABS	Anti-Lock Braking System
ACT	actual; currently present fault
ASR	Anti-Slip-Regulation
CF	Compact Flash (Card)
CLR	cleared
CV	Commercial Vehicle
DIS	Distributed Interactive Simulation; data exchange standard for controlling simulation systems
ECU	Electronic Control Unit
EOBD	European On-Board Diagnostics
EPS	Electronic Power Shift; electro-pneumatic shift control
ESC	Escape; cancellation of initiated actions on the computer
FA	Flight Analyzer; software for analysis
FDR	Flight Data Recorder; data recorder
GND	Ground; Masse, reference potential in electrical engineering
HHT	(Smart) Handheld Tester
ISO	International Organization for Standardization
LCD	Liquid Crystal Display
LED	Light Emitting Diode
M12	12 months
MEM	Memory; stored (not currently present) fault
NR	New Reflex
NTL	No Time Limit
OR	Old Reflex
OTC	The company Owatonna Technical Component
PWR	Power; button for switching on and off
REC	Record

RS232	Recommended Standard 232
SHT	Smart Handheld Tester
SM	Smart Module
SSID	Service Set Identifier; ID of a wireless network
TCP/IP	Transmission Control Protocol/Internet Protocol; network protocol
TEBS	Electronic Braking System for Trailers
TFT	Thin Film Transistor; liquid crystal display
USB	Universal Serial Bus; serial bus system for connecting a computer to external devices
VCS	Vario Compact System
VGA	Video Graphics Array; the VGA connection is an analogy computer display standard for plug and cable connections.
WLAN	Wireless Local Area Network
XD	Expert Diagnostics

1	Symbols used	8
2	Safety instructions	9
3	Usage Terms and Conditions for WABCO XD (diagnostic device / diagnostic software)	10
4	Introduction	13
5	Smart Handheld Tester (SHT)	14
5.1	Safety instructions	14
5.2	Bill of materials "Compact Packages"	14
5.3	Description of the Smart Handheld Tester / Accessories	15
5.4	Initial start-up of the Smart Handheld Tester	17
5.4.1	Battery	18
5.5	General settings	19
5.6	Diagnostics	22
5.6.1	Auto diagnostics function	22
5.6.2	Vehicle specification	23
5.6.3	Diagnostic connections	24
5.6.4	Software activation	26
5.6.5	Carrying out the diagnostics	26
5.6.6	Repair	28
5.6.7	Deleting the diagnostic memory	29
5.6.8	Actual values	29
5.6.9	Actuators test	31
5.7	Flight Data Recorder (FDR)	32
5.7.1	Preparations	32
5.7.2	Recording	33
5.7.3	Data analysis	35
5.8	Scope/Multimeter	37
5.8.1	Connections	37
5.8.2	Scope/Multimeter function	38
5.8.3	Scope	38
5.8.4	Selection of the time basis / voltage scale	41
5.8.5	Synchronisation of a signal	42
5.8.6	Measurement	43
5.8.7	Signal representation	44
6	Smart Module (SM) in connection with the Toughbook	45
6.1	Safety instructions	45
6.2	Part lists Advanced / Premium packages	46
6.3	Description of the Smart Module/Accessories	48
6.4	Commissioning the Smart Module/Toughbook	50

6.5	WLAN	51
6.6	Starting the SmartViewer	53
6.7	System settings	54
6.8	Diagnostics	56
6.8.1	Vehicle specification	56
6.8.2	Diagnostic connections	56
6.8.3	Software activation	58
6.8.4	Carrying out the diagnostics	59
6.8.5	Repair	61
6.8.6	Deleting a fault from the diagnostic memory	62
6.8.7	Actual values	62
6.8.8	Actuators test	63
6.9	Flight Data Recorder (FDR)	64
6.9.1	Preparations	65
6.9.2	Recording	66
6.9.3	Data analysis	68
7	Software	72
7.1	WABCO Diagnostic Software subscription	72
7.2	Download of software updates / upgrades	72
7.3	Install Generic Software Update	74
7.3.1	Smart Module in connection with the Toughbook	75
7.3.2	Smart Handheld Tester	76
8	Repair service	78
9	Disposal	79
10	Annex	80
10.1	Components of the XD packages	80
10.2	Order number of the XD packages 446 302 XXX 0	81
10.3	Smart Cards	82
10.4	Accessory Cases	84
10.5	Kits	86
10.6	Technical data and regulations	87

1 Symbols used

DANGER

Imminent hazard situation which can cause serious personal injury or death if the safety instruction is not observed.

WARNING

Potential hazard situation which can cause death or serious personal injury if the safety instruction is not observed.

CAUTION

Potential hazard situations that can cause minor or moderate to severe injury, or material loss, if the safety instruction is not observed.



Important instructions, information, or tips that you should always observe.

- List
- Step
 - ➔ Consequence of an action

2 Safety instructions

- Read this document carefully. All instructions, notes, and safety instructions must be adhered to in order to avoid personal injury and/or material loss. WABCO will only guarantee the safety, reliability and performance of its products and systems if all information provided in this document is observed. Any deviating procedure may lead to incorrect results on the vehicle.
- Only trained and qualified technicians are permitted to perform work on the vehicle.
- Always follow specifications and instructions of vehicle manufacturer.
- Always comply with the company's regulations for the prevention of accidents and national regulations.
- Wear any necessary protective clothing.
- The workplace has to be dry, well lit and sufficiently ventilated.
- Before you perform any further activities on this system you must query the current fault status again after you have eliminated the fault or have cleared the diagnostic memory. This is the only way to ensure that the fault has been eliminated.
- If you have performed a Service Reset (reset of the date or the odometer reading), you must query the current service status before you perform any other activities on the control unit.

Risk of suffocation!

- Perform diagnostics on vehicles with the engine running only in spaces equipped with an exhaust extraction system, or outdoors.
Breathing in carbon monoxide can cause serious damage to health and even death in enclosed spaces without an exhaust extraction system.

Danger of bodily injury!

- Pedal actions can cause serious injuries if persons are near the vehicle.
Ensure that pedal action is prevented by means of the following measures:
 - Switch the gearbox to "neutral" and actuate the hand brake.
 - Use brake wedges to secure the vehicle against rolling away.
 - Attach a clearly marked note on the steering wheel saying that work is being performed on the vehicle and that the pedal must not be applied.
- Never use the diagnostic devices to actuate components (actuator test) when persons are present within the danger zone of the component to be actuated.
- Do not wear a tie, wide clothing, open hair, bracelets or watches, etc. when working on the vehicle, especially if the engine is running. Keep your hands and hair away from moving parts.

Fire hazard!

- Only use lamps with a ground connection.
- Keep flammable material (cloth, paper, etc.) away from the exhaust system.
- Do not smoke at your workplace.
- Check the electrical lines to make sure they are properly insulated and fastened.

3 Usage Terms and Conditions for WABCO XD (diagnostic device / diagnostic software)

1.

WABCO Fahrzeugsysteme GmbH (hereinafter referred to as "WABCO") permits you to use the WABCO XD diagnostic device as well as the WABCO XD diagnostic software exclusively in accordance with the following terms and conditions (hereinafter referred to as "Usage Terms and Conditions"), which are supplemented by the provisions of the respective WABCO End User License Agreement (EULA).

2.

WABCO hereby emphatically points out to you that

- the system diagnostics carried out with the WABCO XD diagnostic device and the WABCO XD diagnostic software (such as the read-out and deletion of the fault memory, control of components, service reset, calibration, brake pad replacement, etc.) enables, among other things, the motor control, comfort and safety (hereinafter referred to collectively as "Vehicle Systems") of the vehicle to be examined, influenced and altered (hereinafter referred to collectively as "System Diagnostics"). In order to properly use the WABCO XD diagnostic device and the WABCO XD diagnostic software, all (warning) labels, instructions, testing standards and other information which are prescribed in the operating manual of the WABCO XD diagnostic device or in the use of the WABCO XD diagnostic software must be conscientiously followed;
- the system diagnostics possible with the WABCO XD diagnostic device and the WABCO XD diagnostic software may be undertaken exclusively in accordance with and subject to the conscientious adherence to the operating manuals, instructions, original manufacturer's repair guidelines, (warning) labels, testing standards and other information prescribed by the respective vehicle manufacturer or (system) supplier for the Vehicle System and, before using the WABCO XD diagnostic device and the WABCO XD diagnostic software, particularly the conformance of the respective vehicle model with the setting requirements and service recommendations of the respective manufacturer or (system) supplier must be ensured;
- in the event of damaged or functionally restricted control devices, the loss of data by the vehicle owner or doubts regarding the identification of the control device and the conformance of the vehicle model to the setting requirements and service provisions, system diagnoses may be carried out exclusively in an authorised contractual workshop of the respective vehicle manufacturer or (system) supplier because the information and required data for the risk-free execution of the system diagnostics can only be recovered or any doubts eliminated only by acting in such a precise and safe manner;
- prior to the completion of the system diagnostics, all vehicle systems and their functions must be completely and properly reactivated;
- use of the WABCO XD diagnostic device and the WABCO XD diagnostic software by a user who does not have the suitable knowledge and skills required for the system diagnostics of the Vehicle Systems installed in the vehicle may lead to a restriction of the vehicle's safety and functionality which endangers the life and limb of third parties and, for this reason, training in the use of the WABCO XD diagnostic device and the WABCO XD diagnostic software on the one hand (WABCO offers such instruction in the form of training programmes, contact: WABCO University) as well as the acquisition of the suitable knowledge and skills required for the execution of a system diagnostics on the Vehicle Systems installed in the vehicle are mandatorily required prior to the use of the WABCO XD diagnostic device and the WABCO XD diagnostic software on

the other hand (for example, by participating in training courses of the vehicle manufacturer or the (system) supplier or technical training).

3.

You confirm that you are aware of the provisions of Clause 2 and undertake to adhere to them and any subsequent standards prescribed for the use of the WABCO XD diagnostic device and the WABCO XD diagnostic software. Upon your acceptance of these Usage Terms and Conditions, you moreover confirm that you have acquired the suitable knowledge and skills required for the system diagnostics of the Vehicle Systems installed in the vehicle through the participation in technical training and special training conducted by WABCO, the vehicle manufacturers or (system) suppliers or that you will acquire them before you use the WABCO XD diagnostic device and the WABCO XD diagnostic software.

In the event that the WABCO XD diagnostic device and the WABCO XD diagnostic software are not supposed to be used exclusively by you, but also by other persons in your company, you are obliged to ensure that these persons are informed of the provisions specified above in Clause 2, that they adhere to them and any subsequent standards prescribed for the use of the WABCO XD diagnostic device and the WABCO XD diagnostic software. In this case, you shall also be obliged to ensure that these persons have the suitable skills and knowledge required for the execution of the system diagnostics of the Vehicle Systems installed in the vehicle or that they acquire these skills and knowledge before they use the WABCO XD diagnostic device and the WABCO XD diagnostic software. You are not permitted to allow persons to use the WABCO XD diagnostic device and the WABCO XD diagnostic software who are not affiliated to your company.

4.

You undertake to ensure that persons who do not fulfil the requirements specified in Clause 3 of these Usage Terms and Conditions at no time have access to the WABCO XD diagnostic device or the WABCO XD diagnostic software.

5.

You undertake ensure that you, or the persons authorised for usage in accordance with Clause 3 of these Usage Terms and Conditions, completely and properly reactivate all vehicle systems and their functions before the completion of the system diagnostics.

6.

You shall be liable for the adherence to and fulfilment of the provisions specified in the aforementioned Clause 2 and any subsequent standards prescribed for the use of the WABCO XD diagnostic device and the WABCO XD diagnostic software. Furthermore, you shall be liable for adherence to the obligations for the use of the WABCO XD diagnostic device and the WABCO XD diagnostic software that are specified in the aforementioned Clauses 3 to 6.

Furthermore, you shall be liable for the adherence to and fulfilment of the aforementioned provisions specified in Clauses 2 to 6, the subsequent standards prescribed for the use of the WABCO XD diagnostic device and the WABCO XD diagnostic software as well as the aforementioned obligations upon the part of the persons authorised for usage in accordance with Clause 3 of these Usage Terms and Conditions.

7.

You undertake to indemnify WABCO and the companies of WABCO Group from any liability for damages caused by the incorrect or improper usage, the non-adherence to the provisions specified in Clauses 2 to 6, including any subsequent standards prescribed for the use of the WABCO XD diagnostic device and the WABCO XD diagnostic software as well as any other obligations.

Furthermore, you undertake to indemnify WABCO and companies of WABCO Group from all damage compensation claims by third parties, the cause of which

lies in your sphere of dominion and organisation and that you are liable yourself in the external relationship. This shall also apply with regard to the persons authorised for use in accordance with Clause 3 of these Usage Terms and Conditions.

8.

The law of the Federal Republic of Germany shall apply, subject to the exclusion of the United Nations Convention on Contracts for the International Sale of Goods. If you are an entrepreneur listed in the Commercial Register or have no general legal venue in the Federal Republic of Germany, the legal venue for all legal disputes arising from or in conjunction with these Usage Terms and Conditions shall be the commercial residence of WABCO. However, WABCO shall be entitled to also take legal action in the court which is competent for your company's commercial residence.

4 Introduction

WABCO Expert Diagnostics (XD) is an universal tool that was designed for operation in a workshop. It permits the diagnostics of electronic systems in light- and heavy-duty commercial vehicles, trailers, and buses, and optionally of systems in passenger cars and motorcycles.

Apart from passive functions such as reading out and clearing fault memories and the display of actual values, WABCO XD can also be used to perform active diagnostics. This includes, for example, a Service Reset and the actuation of lamps and valves.

Diagnostic connections can be established to control devices of reputable manufacturers installed in variously configured vehicles with various production dates.

Supported systems include, for example:

- Engine control
- Air suspension
- Brake control
- Gearbox control

Different XD packages are available depending on the requirements of the workshop. Compact is based on a Handheld-Tester, and Advanced and Premium packages on a laptop with vehicle interface. The Premium package includes a robust trolley with a docking station for the Toughbook preassembled. The necessary diagnostic cables are kept in the cable cases.

The Toughbook has an open operating system so that it can be used for other workshop and office applications. The option of a wireless connection to the laptop is also provided. The operating system and Generic Software are already installed.

In addition to the universal software, the complete package also includes a subscription for the WABCO system diagnostics or a renewal of an existing subscription for one year.

A comprehensive WABCO service with on site support in the case of first use if required, help desk, hire and replacement service is also part of the XD packages.

The table on the next page provides an overview of the components of each design. The XD software can be downloaded from the Internet without access data. The XD hardware is activated via Smart Cards. These enable executing the setup for a certain number of updates or a specific period of validity for the diagnostics.

5 Smart Handheld Tester (SHT)

5.1 Safety instructions

It is essential that the following points be observed to ensure that the Smart Handheld Tester functions smoothly:

CAUTION



Damage to the Smart Handheld Tester due to improper use

- Never use the Smart Handheld Tester in the proximity of heat sources (e. g. heater, oven), exhaust gases, magnetic fields, or current sources.
- Do not expose the Smart Handheld Tester to impact, shock or moisture (water or other liquids).
- Never repair or service the inside components yourself, but take it to your WABCO dealer.

5.2 Bill of materials "Compact Packages"



Please check your Compact package for completeness. With the purchase of the Compact package you should have received the parts listed in the table below. If the package is incomplete, please contact your WABCO partner.

Compact package		
Parts	Product number	✓
Smart Handheld Tester case (incl. accessories) *)	446 302 011 0	
Generic Software for Smart Handheld Tester (already installed)	246 302 003 0	
Smart Card for Smart Handheld Tester (for first enabling)	446 302 017 0	
Cable set Generic (towing vehicle, bus, trailer) case *)	446 302 020 0	
XD User Manual (en)	815 010 111 3	

*) The parts of the cable set case are listed in the annex.

5.3 Description of the Smart Handheld Tester / Accessories

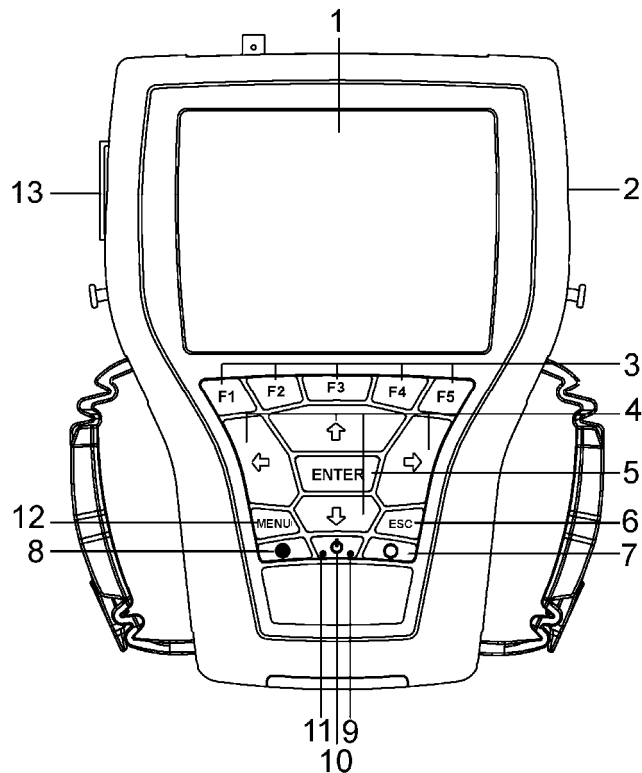

No.	Component	Description
1	LCD	Display
2	Read-in unit	For receiving the Smart Card
3	F1-F5 keys	These keys are coupled with the functions shown as symbols at the bottom of the display (the function bars).
4	Arrow keys	The arrow keys allow cursor movement in four directions (upwards, downwards, to the right and to the left)
5	ENTER key	Confirmation key
6	Button ESC	For exiting the display pages/for cancelling processes
7	"Lower contrast" button	Lower the display contrast
8	"Increase contrast" button	Increase the display contrast
9	Green LED	Green steady light: Power supply from the vehicle Flashing green: Internal battery supply
10	POWER key	Switches the Smart Handheld Tester ON/OFF
11	Red LED	Red steady light: The battery is charged or the Smart Handheld Tester is being supplied by the power supply unit. Flashing red: The battery is being charged.
12	MENU key	For calling up the function bars
13	Read-in unit	For receiving the Compact Flash Card (CF)

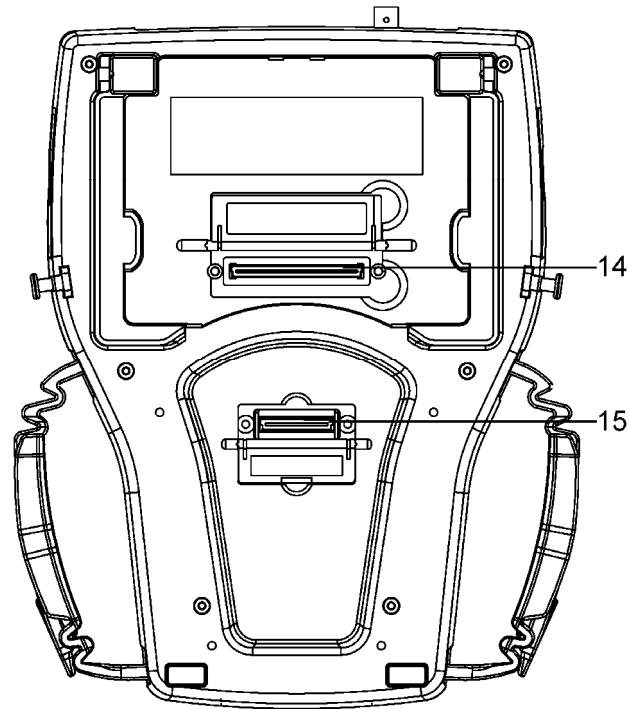

No.	Component	Description
14	Connection	Connection facility for a 4-channel oscilloscope
15	Connection	For future communication upgrades

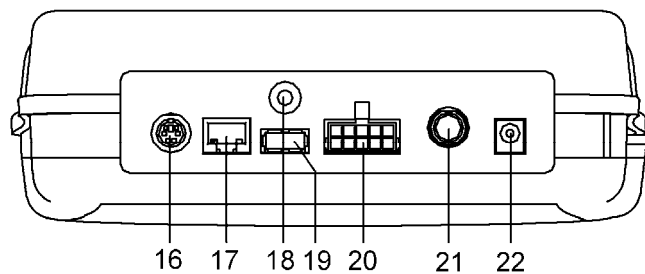

No.	Component	Description
16	VGA-Connection	Connection facility for a standard VGA monitor
17	RS232-Connection	Connection facility for devices such as the Toughbook
18	GND-Connection	Connection for vehicle grounding
19	USB-Connection	Connection for such things as a printer
20	ECU-Connection	Connection for an extension cord
21	Oscilloscope connection	Connection facility for a 1-channel oscilloscope
22	Power supply unit connection	Connection facility for the external power supply of the Smart Handheld Tester)

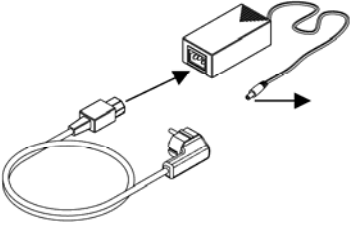
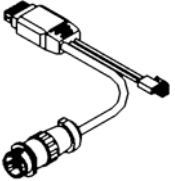
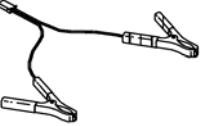
Accessories	Description
Power supply unit (mains cable + power supply) 	For connecting up the Smart Handheld Tester to the network
Extension cable 	For connecting up to the Smart Handheld Tester
Battery cable 	For connecting to the Smart Handheld Tester to the vehicle battery (external power supply)

5.4 Initial start-up of the Smart Handheld Tester

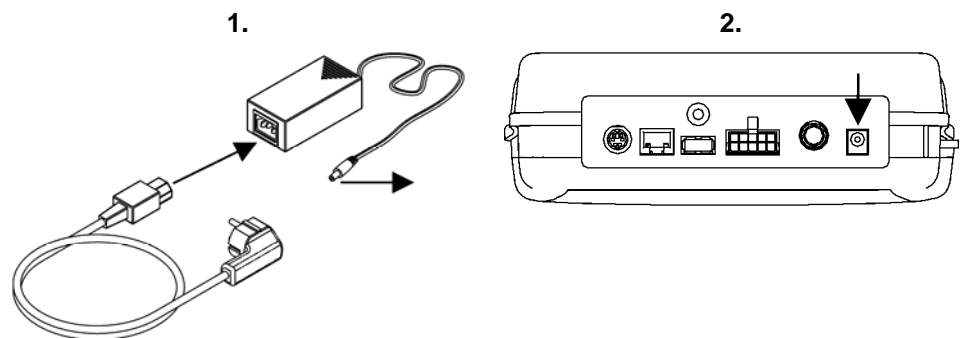

Connections

- Connect the power supply unit with the mains supply (1.).
- Connect the mains cable to the connection on the power supply unit on the Smart Handheld Tester (2.).
- Connect the power supply unit with the mains supply.

Switch on Smart Handheld Tester

- Press .
- The WABCO start page appears.

Switch off Smart Handheld Tester

- Press  until the green LED (to the right of ) goes out.

5.4.1 Battery

! Batteries inside the Smart Handheld and Smart Module are consumables and not covered by the warranty.

Charge battery

When the *Battery charge* message appears, please do the following:

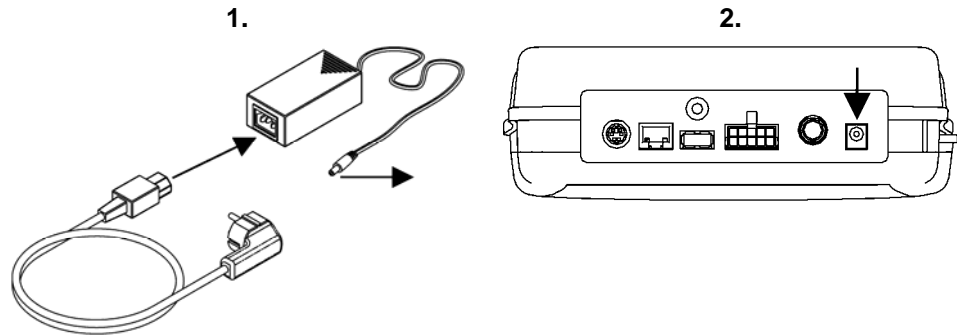



- Connect the power supply unit with the mains supply (1.).
- Connect the mains cable to the connection on the power supply unit on the Smart Handheld Tester (2.).
- Connect the power supply unit with the mains supply.
- ➔ The red LED (to the left of ) starts to flash.
The red LED goes off as soon as charging is completed.
Charging 2,000 mAh batteries takes about 2.5 hours.

Prevent battery overload

! Do not charge when the Smart Handheld Tester is connected to the vehicle. Only use the supplied power supply unit + supply cable for charging.

Check the battery charge

- Briefly press  to switch on the Smart Handheld Tester.
➔ The WABCO start page appears.
- Press MENU to invoke the function bar 1.
- Press F3 ()
➔ During the charging process, *Maintenance* is displayed over the button and the battery symbol.

Restoring

Preventing the "memory effect"; the Smart Handheld Tester only works with the power supply unit.

The button next to the battery symbol is red while restoring (see following figure).

Once the restoring process is complete, the battery symbol is crossed out.

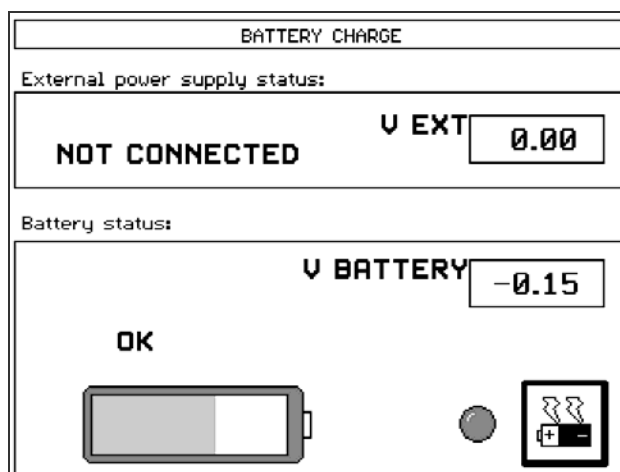

The charger receives the battery charge if there is a power supply (for instance, with the supplied power supply unit or the diagnostic connection in the vehicle).

Back to function bar 1

- Press ESC.

5.5 General settings

Before you begin with the diagnostics, please make general settings (such as time, language).

Where and how to make these general settings is described in more detail in the sections below.







Switch on Smart Handheld Tester

- Press .
- The WABCO start page appears.

Call up function bar 1

















- Press MENU.
- The function bars consist of five consecutive symbols (in the lower section of the display).

The F1 - F5 keys are used to start these functions.

Function bar 1		
Function	Description	Procedure:
F1 	Open Application manager (for selecting the functions <i>Autodiagnostics</i> , <i>Scope/Multimeter</i> , <i>Flight Analyzer</i>)	Press F1 to invoke the function. Press ESC to return to function bar 1.
F2 	Make energy saving setting	Press F2 to invoke the function. <i>VAG (ON/OFF)</i> : The monitor is switched off automatically when this option is checked. <i>Beeper (ON/OFF)</i> : The key tone is activated when this option is checked. <i>xx minutes to auto power off</i> : You can define after how many minutes the Smart Handheld Tester should switch itself off. <i>xx minutes to autom. power off display</i> : You can define after how many minutes the Smart Handheld Tester should switch itself off. Press ESC to return to function bar 1.
F3 	Check power supply/battery status see chapter 5.4.1 "Battery", page 18	Press F3 to invoke the function. Press ESC to return to function bar 1.
F4 	Open a description of the hotkeys the Smart Handheld Tester applications	Press F4 to invoke the function. Use   to navigate up and down within the text. Press ESC to return to function bar 1.
F5 	Call up function bar 2	Press F5 to invoke the function.













Call up function bar 2

– Press F5.

Function bar 2		
Function	Description	Procedure:
F1 	Select language	<p>Press F1 to invoke the function.</p> <p>Use   to select the desired language and validate with F5.</p> <p>Select  using   and confirm with ENTER.</p> <p>Press ESC to return to function bar 2.</p>
F2 	Select summer and winter time	<p>Press F2 to invoke the function.</p> <p>Press F1 to select summer or winter time.</p> <p>Select  using   and confirm with ENTER.</p> <p>Press ESC to return to function bar 2.</p>
F3 	Enter workshop data (e. g. address)	<p>Press F3 to invoke the function.</p> <p>Select the desired character using  .</p> <p>Use   to mark the next/previous character.</p> <p>Press ESC to return to function bar 2.</p>
F4 	Select printer	<p>Press F4 to invoke the function.</p> <p>Press ESC to return to function bar 2.</p>
F5 	Call up function bar 3	Press F5 to invoke the function.

Call up function bar 3

- Press F5.

Function bar 3		
Function	Description	Procedure:
F1 	File management: A list of the installed files with file size, version, type and date	Press F1 to invoke the function. Use   to navigate between drives. Press ESC to return to function bar 3.
F2 	Setting date and time	Press F2 to invoke the function. Use   to select the desired digit. Use   to mark the next/previous character. Press ENTER to jump to the next field. Select  using   and confirm with ENTER. Press ESC to return to function bar 3.
F3 	Call up system information on the Smart Handheld Tester (e. g. serial number, hardware design, and the operating system)	Press F3 to invoke the function. Press ESC to return to function bar 3.
F4 	Self-test for checking the hardware (e. g. the function keys)	Press F5 to invoke the function. Press ESC to return to function bar 3.

5.6 Diagnostics

Switch on Smart Handheld Tester

- Press .
- ➔ The WABCO start page appears.

5.6.1 Auto diagnostics function

Call up the *Application manager*

- Press any key (except  and MENU) to open the *Application manager*.
- The *Application manager* page shows three menu items for selection:
- *Autodiagnostics*
 - *Scope/Multimeter*
 - *Flight Analyzer*

Select *Autodiagnostics* function

- Select the *Autodiagnostics* function with  .



- Validate this selection with ENTER.

5.6.2 Vehicle specification

The following menu items are available for selection:

- *Passenger cars*
- *Motorcycles*
- *Trucks*
- *EOBD/OBDII*





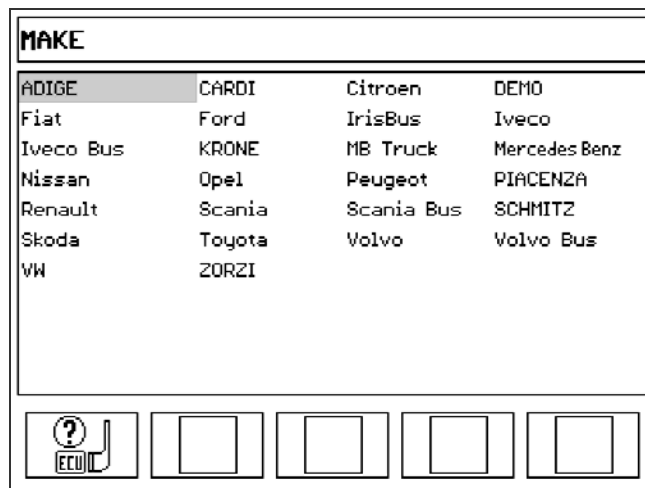











Example Trucks

- Use   to select the menu item *Trucks*.
- Validate this selection with ENTER.



The programme calls up the *Make* page where you can select the vehicle manufacturer. The pages below run through other vehicle characteristics (such as the model or system type).

Specify the vehicle

- On the page *Make*, use   and/or   to select the make (e. g. Mercedes Trucks).
- Validate this selection with ENTER.
- On the page *Model*, use   and/or   to select the model (e. g. Actros).
- Validate this selection with ENTER.
- Select the system on the *System type* page (for instance, ABS) that you would like to test using   and/or  .
- Validate this selection with ENTER.
- On the page *Motor/System*, use   and/or   to select the vehicle type (e. g. 1831).
- Validate this selection with ENTER.
- When the *ECU* appears, confirm with ENTER.

5.6.3 Diagnostic connections

Position of the diagnostic connection and / or the ECU in the vehicle

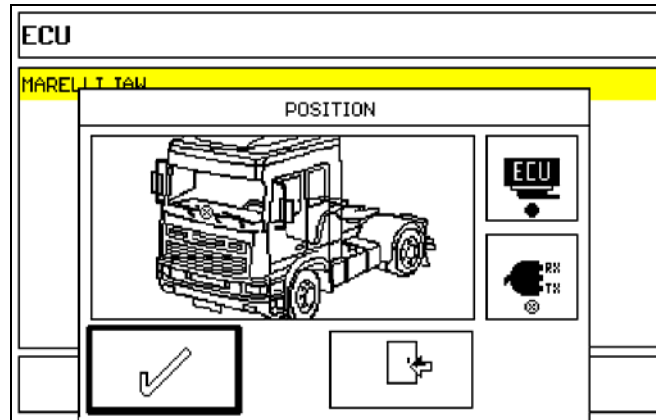

The *Position* page shows the approximate position of the diagnostic connection and / or the ECU in the vehicle.

Flashing blue dot: Approximate position of the diagnostic connection

Flashing red dot: Approximate position of the ECU

Adapter cable

- Confirm with ENTER.

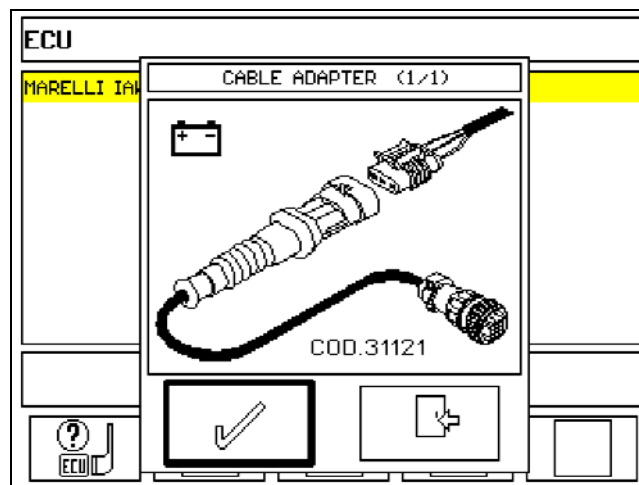

- The *Cable Adapter* page appears. You will see a figure of the multiswitch and the specific adapter cable for the vehicle + code (COD.XXXXX).

Connections

- ! When downloading new software from the Internet, new cables may also be necessary in some cases. Please contact your WABCO partner. Only use the adapter cables suggested by the diagnostic programme. There are different diagnostic connections in the vehicle depending upon the vehicle manufacturer. Different manufacturers may use different jack types.



	<p>When the battery symbol appears on the <i>Cable Adapter</i> page (at the top left), connect the battery cable to the battery of the vehicle to be tested and connect it to the extension cable.</p>
	<p>When the crossed out battery symbol is visible on the <i>Cable Adapter</i> page (top left), the battery cable must not be connected to the extension cable in order to avoid interferences in the diagnostic connection. The Smart Handheld Tester is supplied directly with power through the diagnostic connection in the vehicle.</p>

- Turn off ignition.
- Connect the extension cable to the "Multiswitch".
- Connect the "Multiswitch" to the vehicle-specific adapter cable.
- Connect the adapter cable for the vehicle to the diagnostic connection in the vehicle.
- When you have made the connections, confirm with ENTER:
- Observe the warning notices below.
- Press ENTER to continue.

5.6.4 Software activation

The *Software Activation* page appears.

The software is already activated

- If the software is already activated, a message appears that you only need to acknowledge with ENTER.

Enabled during initial start-up of the Smart Handheld Tester or when the user licence has expired

- Insert the Smart Card into the read-in unit of the Smart Handheld Tester. Make sure that the writing on the Smart Card is facing upwards and the black tip of the arrow (on the Smart Card) is pointing in the direction of the opening on the read-in unit.

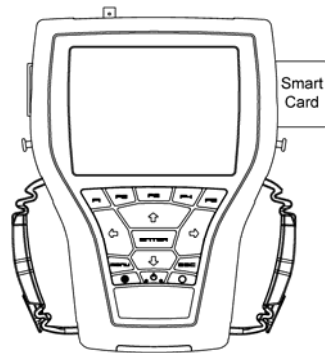

- Follow the programme instructions.
 - ➔ The Smart Card is "erased" when the licence is confirmed and can not be used again thereafter.
 - You get information on the installed programme design and your personal clearance code.
- Confirm with ENTER.
- Remove the Smart Card.

5.6.5 Carrying out the diagnostics

! Before you begin with the diagnostics, please read the safety instructions, see chapter 2 "Safety instructions", page 9 above and make sure that you follow these instructions.

All instructions, notes, and safety instructions must be adhered to during diagnostics to avoid personal injury or material loss. Any deviating procedure may lead to incorrect results on the vehicle.

Open the *Fault Codes* page

- Follow the display instructions until the connection has been established between the Smart Handheld Tester and ECU.
 - ➔ The *No fault detected* message appears if the ECU does not report any faults.
 - When the ECU reports faults, the *Fault Codes* page appears.

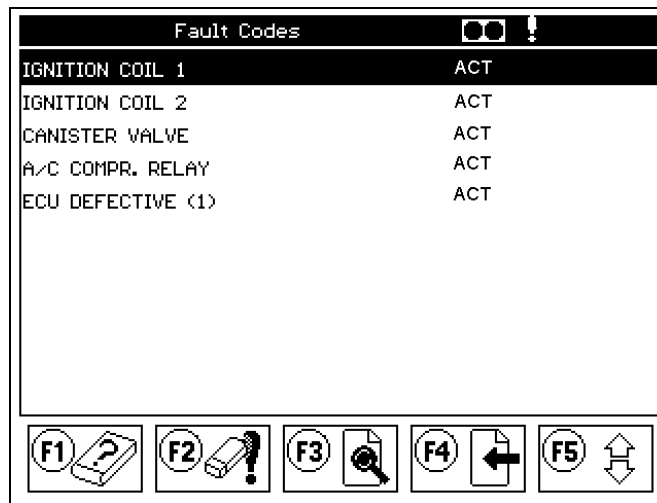





	Operating status indicator (green): A flashing signal indicates the operating status "Diagnostics"	ACT	Currently present faults
	Red exclamation mark, together with a signal tone: A current ECU fault message is present	MEM	Fault is present but not current (stored)

Function bar 4		
Function	Description	Procedure:
F1 	Call help texts on selected value	Press F1 to invoke the function. Press ESC to return to function bar 4.
F2 	Clearing the diagnostic memory	Press F2 to invoke the function. Press ESC to return to function bar 4.
F3 	Enlarge view (Zoom function)	Press F3 to invoke the function. Press ESC to return to function bar 4.
F4 	Open <i>Live Data</i> and <i>Actuator Tests</i> pages	Press F4 to invoke the function. Press ESC to return to function bar 4.
F5 	Change the sequence of system data	Press F5 to invoke the function. Press ESC to return to function bar 4.

Function bar 5

- Press MENU.

Function bar 5		
Function	Description	Procedure:
F1 	Call information on the ECU	Press F1 to invoke the function. Press ESC to return to function bar 5.
F2 	Call system information	Press F2 to invoke the function. Press ESC to return to function bar 5.
F3 	Call "Flight Data Recorder" function	Press F3 to invoke the function. Press ESC to return to function bar 5.
F4 	Open Printer menu	Press F4 to invoke the function. Press ESC to return to function bar 5.
F5 	Open the <i>Application Manager</i>	Press F5 to invoke the function. Press ESC to return to function bar 5.

5.6.6 Repair

CAUTION**Danger of bodily injury!**

Pedal actions can cause serious injuries if persons are near the vehicle.

Ensure that pedal action is prevented by means of the following measures:

- Switch the gearbox to "neutral" and actuate the hand brake.
- Use brake wedges to secure the vehicle against rolling away.
- Attach a clearly marked note on the steering wheel saying that work is being performed on the vehicle and that the pedal must not be applied.





Before you begin with the repair, please read the safety instructions, see chapter 2 "Safety instructions", page 9 above and make sure that you follow these instructions.



Before you perform any further activities on this system you must query the current fault status again after you have eliminated the fault or have cleared the diagnostic memory. This is the only way to ensure that the fault has been eliminated.

Perform repair(s)

- Turn off ignition before starting any repair work.
- Perform the repair(s).
- After you have successfully completed the repair(s), press any key (except  and MENU).

Perform diagnostics

- Select the *Autodiagnostics* function with  .
- ➔ The rotating symbol on the right-hand side next to *Autodiagnostics* shows that diagnostics is still active.

- Use   to select the menu item *Trucks*.
- Validate this selection with ENTER.
- The *Fault Codes* page is opened again.

5.6.7 Deleting the diagnostic memory

! Before you perform any further activities on this system you must query the current fault status again after you have eliminated the fault or have cleared the diagnostic memory. This is the only way to ensure that the fault has been eliminated.

After the successful repair, you should clear the diagnostic memory. Proceed as follows:

Clearing the diagnostic memory

- Press F2 () to initiate clearing the diagnostic memory.
 - Follow the instructions.
 - After the diagnostic memory has been cleared, CLR (cleared) appears behind the fault message.
- If the fault reoccurs even though it was cleared, check whether the problem may be attributed to other factors (including the ECU).

Remedy in the event of message *Test disabled w/ running engine*

- Exit the programme using the hotkey MENU + ESC.
- Restart the programme without starting the motor.
- Follow the instructions.



5.6.8 Actual values

Display actual values

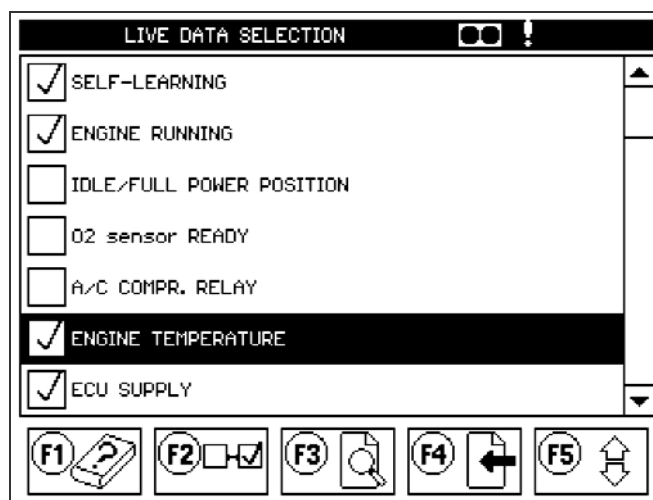
- Press F4 ()
- The *Live Data Selection* page appears.





Select actual value(s)

- Use   to select the values that you want to display.

- Confirm any selection with ENTER.
→ marks a selected actual value.

Deselect actual value

- To remove , use   to reselect the actual value and confirm with ENTER.

Call system data



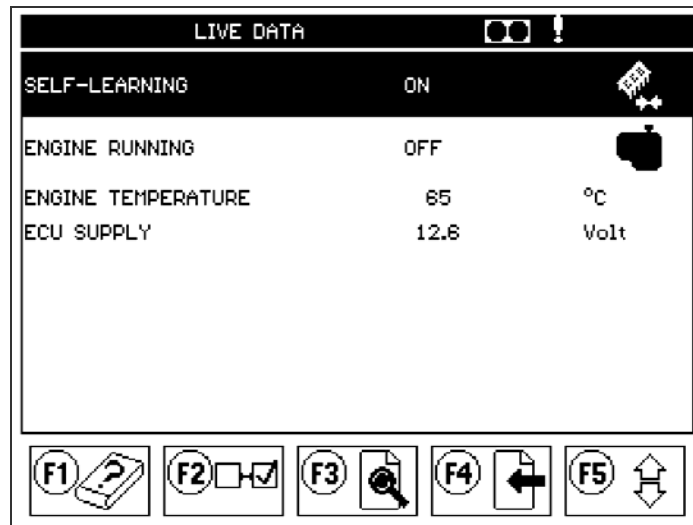

- To display the selected system data, press F2 ().
→ The *Live Data* page appears.



Various data represent the system states.

ON is seen behind active inputs. OFF is seen behind inactive inputs.

Change the order of system data

- Use   to select the data set you want to move.
- Press F5 ().
→ F5 changes the key assignment.
- You can use   to move the selected data set.
- Pressing F5 a second time will reset the key assignment again.

Show graphic curve associated with data set

- Press ENTER with every selected data set to display a graphic curve.
→ The following page appears.

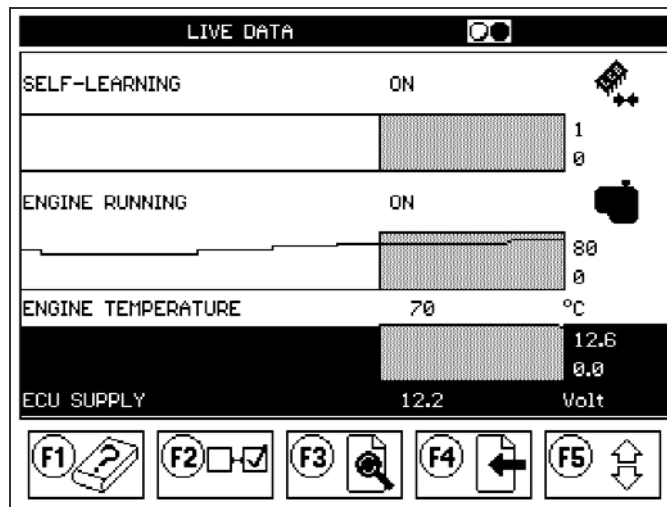

Move graphic curve

- Use to select the graphic curve you want to move.
- Press F5 ().
- F5 changes the key assignment.
- You can use to move the selected graphic curve.
- Pressing F5 a second time will reset the key assignment again.

! How fast the data selected are updated depends on the ECU. The greater the amount of system data, the slower the display is updated. You should therefore select fewer system data for ECUs with reduced capacity.

5.6.9 Actuators test

! The *Actuators Test* function energises all actuators. Only trained and qualified personnel may perform this function. Read the help texts in the programme prior to every test.

WARNING Danger of bodily injury!





- Never use the diagnostic devices to actuate components (actuator test) when persons are present within the danger zone of the component to be actuated.

Invoke actuator test

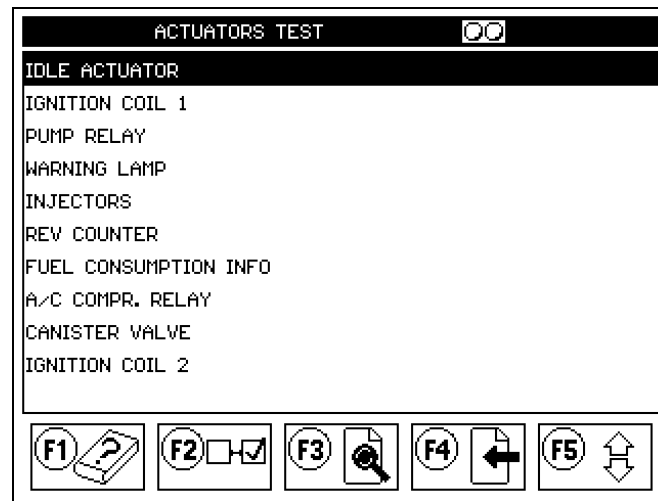
- Press F4 ().
- The *Actuators Test* page appears.



Start actuators test

- Use  to select the desired actuator.
- Click  to call up help texts on the selected actuator.
- Ensure that there is no one in the danger zone of the actuator to be energised.
- Click  to start the test for the selected actuator.
 - ➔ A message appears on the display indicating the test is in progress.

5.7 Flight Data Recorder (FDR)

The Flight Data Recorder is an optional kit 446 302 078 0 consisting of the Smart Card 446 302 089 0 and the Compact Flash Card 446 302 060 0.

This kit can be used to capture and record data from the electronic control units during autodiagnosics, also during a test drive. The data is recorded continuously and over the entire period of communication with the vehicle.

The Flight Data Recorder is an additional function that was integrated into the Smart Handheld Tester (ECUreader/ECUdecoder). No further hardware is required.

When the Flight Data Recorder is activated, the Smart Handheld Tester saves the development of faults, as well as the actual value selected at the time of activation, to the Compact Flash Card.

After recording, the Flight Analyzer (FA) can be used to load the record files from the Compact Flash Card to the Smart Handheld Tester for a graphical analysis of the stored curve traces.

5.7.1 Preparations

Insert Compact Flash Card

- Before you switch on the Handheld Tester and before you perform the diagnostics, insert the Compact Flash (CF) Card 446 302 060 0 into the read-in unit. In the course of a normal diagnostics, the control device data is saved by the Flight Data Recorder.

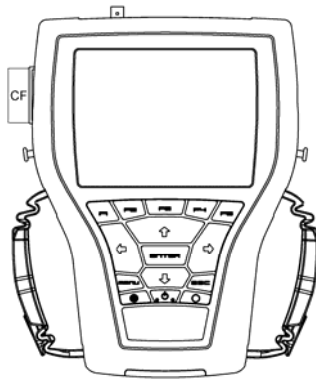

Perform diagnostics

- Perform a diagnostics, see chapter 5.6.5 "Carrying out the diagnostics", page 26.
- Select the function *Live Data*.
- Press F2.
 - ➔ The *Live Data Selection* page appears.
- Press MENU.

Enable Flight Data Recorder

After the check for activation of the ECUreader/ECUdecoder has been passed, two additional buttons enable the display of the activation status of the Flight Data Recorder on the Smart Handheld Tester and, where this is applicable, the start of the activation procedure for the Flight Data Recorder.

The unlock page of the Flight Data Recorders shows the programme version and the Personal ID number and waits for the input of the Smart Card 446 302 089 0 (can be ordered separately from your WABCO partner), for the unlock code, or pressing the ESC key. After this, the procedure is the same as the procedure for the ECUreader/ECUdecoder.

- Press  to open the unlock page of the Flight Data Recorder.
- Insert the Smart Card into the read-in unit and manually enter the unlock code.

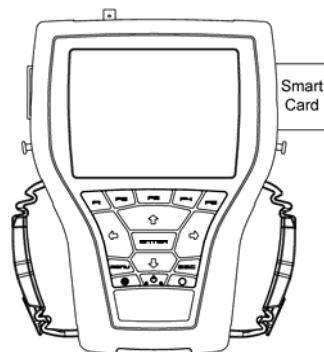

- Follow the instructions.

5.7.2 Recording

Display fault

- Press F3 ().
- ➔ The *Fault Codes* page appears.



is deactivated in the following cases:

- The Flight Data Recorder function was not enabled by means of the Smart Card or the unlock code.
- The diagnostic system is not compatible with the Flight Data Recorder.
- The Compact Flash Card for saving the data was not inserted correctly.

Fault Codes	
COIL 1	MEM
COIL 2	MEM
CANISTER PURGE VALVE	MEM
A/C COMPR. RELAY	MEM
ECU DEFECTIVE (1)	MEM

Start recording

- Press F1 ()

Entering a remark on the recording

- Enter a remark on your recording (to help identify and distinguish the different recordings) on the *Attention* page.

ATTENTION

No help available at present





- Confirm your input with ENTER.

Recording runs

While the recording is in progress, the display shows the message *Recording in Progress*.

The recording process on the Compact Flash Card is indicated by the operating status indicator  flashing.

Should the communication to the control unit be interrupted due to inadvertent or intentional shutdown of the display or the Smart Handheld Tester, the device will automatically attempt (for a maximum duration of 30 minutes) to reconnect when it is switched on again and will then continue the saving process.

Information on the Compact Flash Card

If the Compact Flash Card is not present, the message *Error Compact Flash not found* appears on the display. In this case, the device must be switched off and the Compact Flash Card inserted.

When the Compact Flash Card is removed inadvertently, the Smart Handheld Tester is switched off automatically.

If the storage capacity on the Compact Flash Card is insufficient, the message *Not enough memory for FRT file* appears.

Limit recordings in sections

- Press the symbol with the T.

Stop recording

- To do so, press .



5.7.3 Data analysis

To load and analyse the data that was saved by the Flight Data Recorder the "Flight Analyzer" software is required. This software is preinstalled on the Smart Handheld Tester. This software does not need to be unlocked.

Call up the *Application Manager*



- Press F1 () , to open the *Application Manager* page.

List recordings

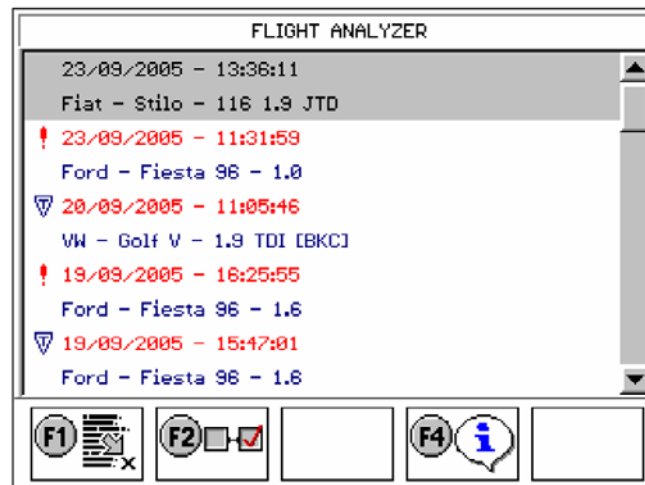

- Use   to select the menu item *Flight Analyzer*.
 - You see a list of the available recordings that were saved to the Compact Flash Card.



Delete recording

- Select the desired recording with  .
- Press F2 () to delete the recording.

Display actual values

- Use   to select the desired recording.
 - Press F2 ()
 - ➔ The page with the recorded actual values appears.
- Faults are indicated by a red exclamation mark in front of the actual value.
If no fault occurred, the actual value is marked by a green checkmark.

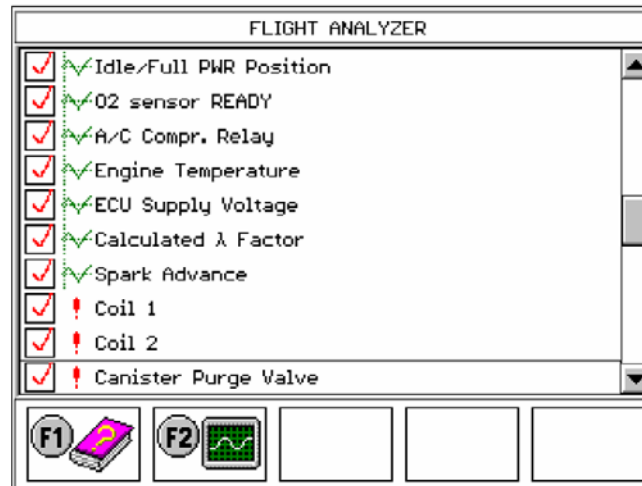

Graphical representation

- Press F2 () to toggle to the graphic view.
 - ➔ The actual values are represented graphically.

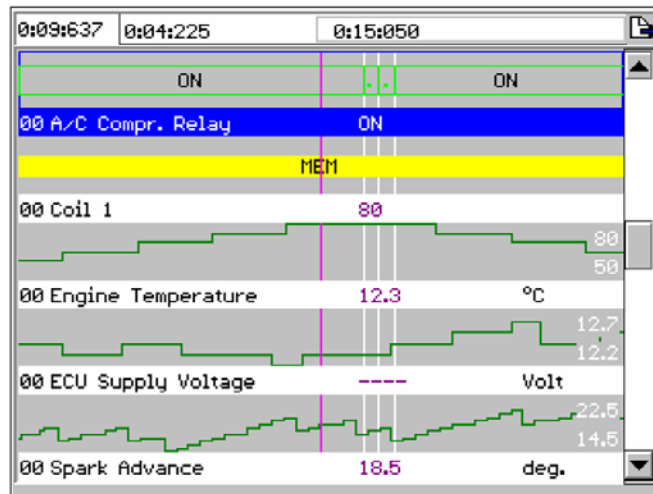







This page provides an overview of the intervals during which the recording was activated and the trigger events.

Current actual values are captured within range of the cursor, which is located at the screen's centre as a vertical line.

Additionally, you can move from step to step, or from page to page, or from trigger to trigger (vertical line next to the cursor).

Hotkeys

Zoom in / out	MENU +  
Previous / Next page	MENU +  
Change the order of actual values	ENTER +   + ENTER

5.8 Scope/Multimeter

5.8.1 Connections

Scope Mode

- Connect the ground cable to the GND connection and to the vehicle frame or to the negative terminal of the battery using the grounding clip or the accessories.
- Connect the included cable to the oscilloscope BNC connector of the Smart Handheld Testers.
- By means of the accessory 2, the probe cable can be used as a function of the respective checks to be made.

Ground cable



Grounding clip



Accessory 1

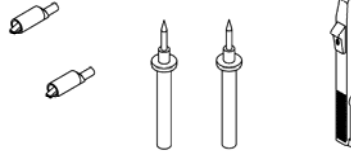

Accessory 2

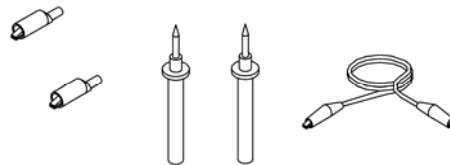

5.8.2 Scope/Multimeter function



Switch on Smart Handheld Tester

- Press .
- The WABCO start page appears.

Call up the *Application Manager*

- Press any key (except  and MENU) to open the *Application Manager*.
- The *Application manager* page shows three menu items for selection:
- *Autodiagnostics*
 - *Scope/Multimeter*
 - *Flight Analyzer*

Invoke *Scope/Multimeter* function

- Select the *Scope/Multimeter* function with  .
- Validate this selection with ENTER.



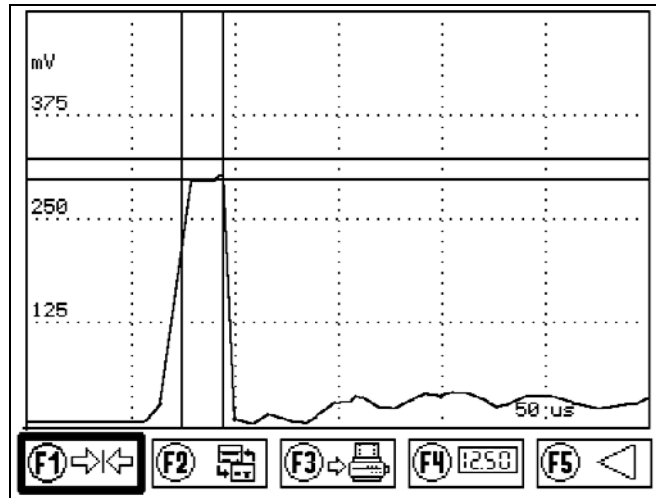

 Before the function is selected for the first time, the software must be unlocked with the Smart Card, see chapter 5.6.4 "Software activation", page 26.

5.8.3 Scope

- Select *Scope* from the choice of instruments.



Function bar 6

Function	Description	Procedure:
F1 	Configuration for determining the voltage scale (Volt) and time basis (time/div.)	Press F1 to invoke the function. Press ESC to return to function bar 1.
F2 	Measure differences in time and voltage between the two points selected on the wave	Press F2 to invoke the function. Press ESC to return to function bar 1.
F3 	Stabilise wave representation (synchronisation of a signal)	Press F3 to invoke the function. Press ESC to return to function bar 1.
F4 	Interrupt data acquisition and print faster.	Press F4 to invoke the function. Press ESC to return to function bar 1.
F5 	Call up function bar 7	Press F5 to invoke the function.

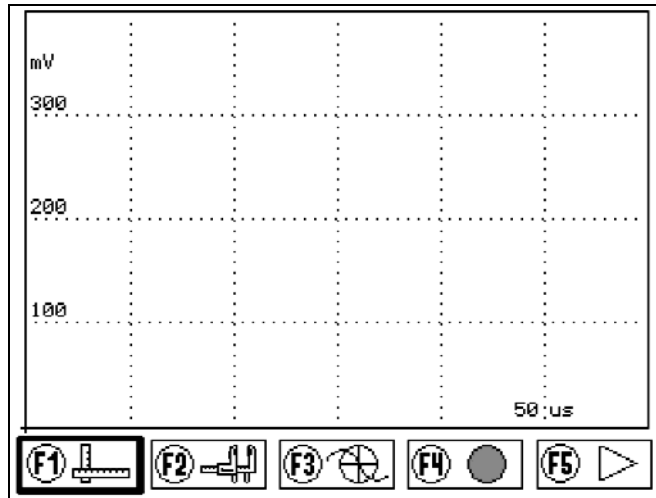

Function bar 7		
Function	Description	Procedure:
F1 	Automatic waveform collection and setting the voltage scale (Volt) and time basis (time/div.)	Press F1 to invoke the function. Press ESC to return to function bar 1.
F2 	Open <i>Application Manager</i> (for selecting the functions <i>Autodiagnos-tics</i> , <i>Scope/Multimeter</i> , <i>Flight Analyzer</i>)	Press F2 to invoke the function. Press ESC to return to function bar 1.
F3 	Open Printer menu	Press F3 to invoke the function. Press ESC to return to function bar 1.
F4 	Display measured values in bottom section of the screen or synchronisa-tion point	Press F4 to invoke the function. Press ESC to return to function bar 1.
F5 	Call up function bar 6	Press F5 to invoke the function.

Open control panel

- Press MENU.
→ The control panel page appears.

Selecting a function

- Select the function via and/or .
- Validate this selection with ENTER.

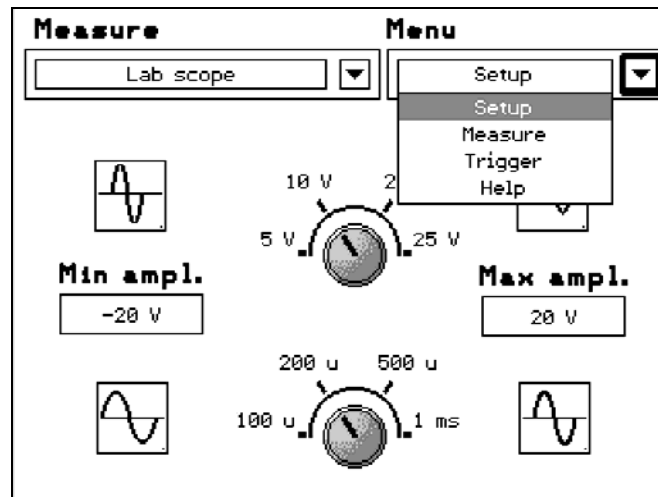



Measurement	
<i>Lab Scope</i>	Manual use of the oscilloscope. Here the read-in parameters are set in relation to the sensor signals and/or switches to be controlled.
<i>Typical curves</i>	If a low voltage curve is selected, the oscilloscope switches into the corresponding visualisation and determines the matching voltage scale and time basis (time/div.).
<i>Primary</i>	Use of the oscilloscope to represent the primary development signal of the ignition system (conventional or DIS) to be controlled.

Menu	
<i>Configuration</i>	A system control is visualised; here the time basis and the voltage scale, primary as well as for each low voltage signal, are set.
<i>Measure</i>	The dropdown menu <i>Cursor selection</i> appears. Here the red and the blue cursors are selected.
<i>Primary</i>	Use of the oscilloscope to represent the primary development signal of the ignition system (conventional or DIS) to be controlled.
<i>Synchron.</i>	The menu <i>Synchron.</i> appears for selecting <i>Unlocked</i> or <i>Block.</i> as well as the <i>Trigger point</i> menu for determining the curve trace for ascending or descending direction.
<i>Help</i>	A diagnostic help and an example for the selected typical curve is visualised.

Exit control panel

- Press MENU or ESC.

5.8.4 Selection of the time basis / voltage scale

- Press F1 () to invoke the function *Configuration*.
- Use   to enter the voltage scale (in volt).

- Use  to enter the time basis (time/div.).



! The values of the voltage scale and the time basis vary relative to the operating mode (Lab Scope or Primary).

5.8.5 Synchronisation of a signal



Synchronisation denotes the stabilisation of the represented wave (signal) on the screen. Synchronisation makes the curve sharper and easier to read.

To achieve a more stable signal it is necessary to enter a sync point (Trigger).

Synchronise the course of the wave

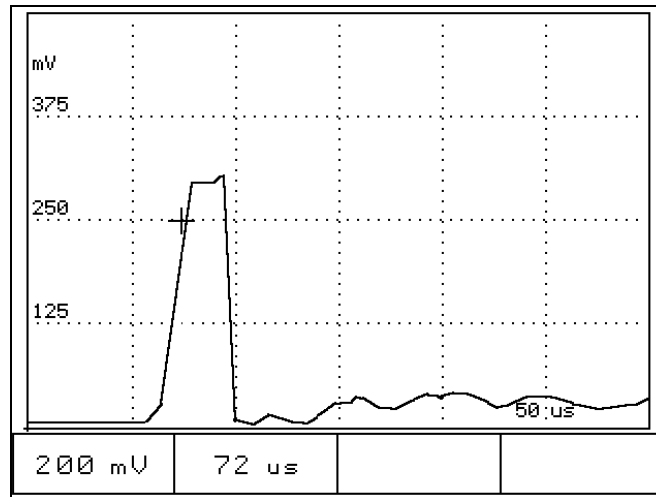
- Press F3 ( ).





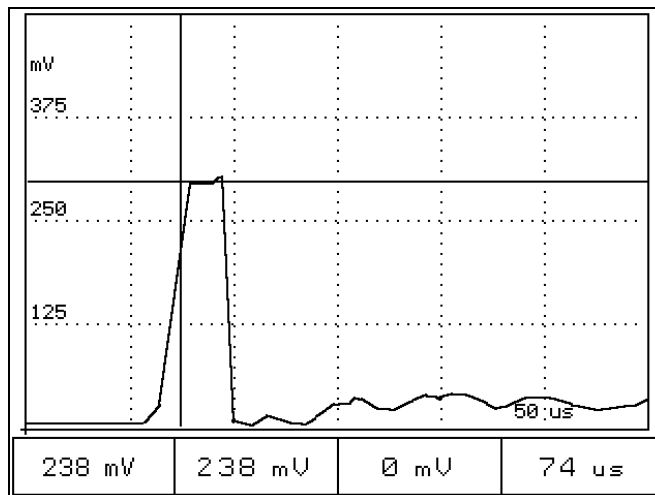

- Use keys  and/or  to move the cross shaped cursor to the desired position.
- Press MENU.
- Select the item *Synchron.* from the submenu to synchronise the ascending or descending course of the wave.

Back to the wave representation page

- Press MENU again.
- The waveform is blocked from the sync point.



Show sync point position in voltage or time value

- While the function F3 (red icon) is selected, press   and or  .
- The signal must be cyclic (periodic) to synchronise it well.

Representation of an extremely irregular signal

- Deactivate the trigger by clicking the Block button in the *Synchron.* menu.

5.8.6 Measurement

The oscilloscope permits measuring differences in time and voltage between two reference points of a signal that is represented on the screen.

Select the function *Measure*



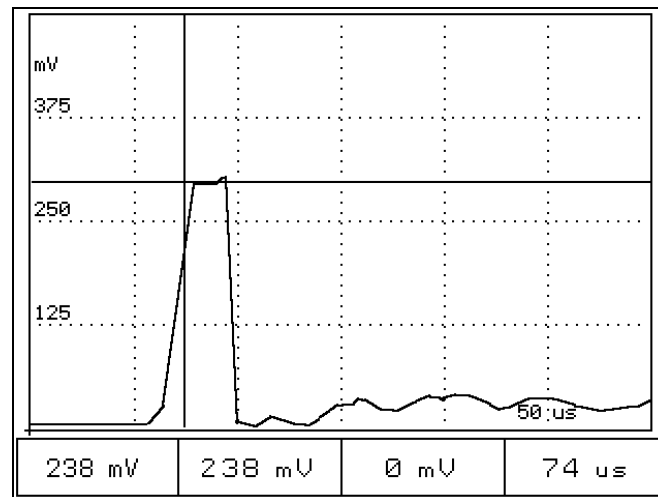

- Press F2 (.
- Press MENU.
- In the submenu *Measure*, select the first cursor (example: blue) that is to be defined as reference for the measurement.

Back to the wave representation

- Press MENU.



Fields	Description
1. Zone: 238 mV	Voltage value of the red cursor
2. Zone: 238 mV	Voltage value of the blue cursor
3. Zone: 0 mV	Voltage difference of the two points
4. Zone: 74 μ s	Time difference of the two points that were defined on the wave path

- Use   and/or   to move the vertical or horizontal row of the previously selected colour (blue).
- Press MENU.
- In the submenu *Measure*, select the second cursor (example: red) that is to be defined as reference for the measurement.
- Press MENU to return to the wave representation.
- This time you position the horizontal and vertical row of the colour Red as described above.

5.8.7 Signal representation

The following must be ensured for the signal representation:

- The instrument must be correctly connected to the vehicle.
- The oscilloscope must be configured accordingly.

During the signal measurement:

- The vehicle or connecting cables must be moved. In the event that the represented signal becomes irregular, the connection may have become weak.
- Check whether the digital waves are without interferences and square.
- Check whether irregularities occur (noise, interferences).

If no signal is received, the connection may be interrupted or short-circuited.

For reception of the desired signals:

- A ground connection must be ensured by means of a good vehicle ground connection.
- The cable must be securely connected to the signal source.