

Luftfedervertil

Levelling Valve

464 007



Zweck:

Das Luftfedervertil steuert die Luftfederbälge, die für die für den Fahrkomfort im Fahrerhaus zuständig sind.

Einbauempfehlung:

Das Luftfedervertil wird mit zwei Schrauben M8 am Chassis in der Nähe des Fahrerhauses eingebaut. Zur Erleichterung der Montage und Einstellung von Hebel und Verbindungsgestänge kann die Luftfedervertilwelle durch Einstecken eines Dorns in der Neutralstellung fixiert werden.

Purpose:

The levelling valve controls the air suspension bellows responsible for driving comfort.

Installation Requirements:

The Levelling Valve is fastened to the chassis by means of two bolts M8. To simplify the installation and the adjustment of the lever and the connecting linkage, the unit can be locked into its neutral position by means of pin.

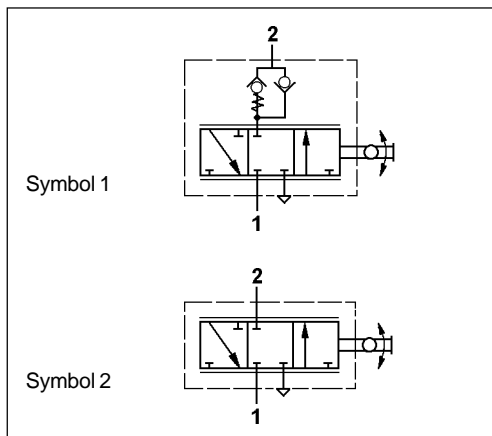

Technische Daten / Technical Data:			
Bestellnummer Part Number	464 007 001 0	464 007 009 0	464 007 011 0
Betriebsdruck (Vorrat) Operating Pressure (supply)	max. 11 bar	max. 10 bar	max. 12,5 bar
Zulässiges Medium Permissible Medium	Luft / air		
Thermischer Anwendungsbereich Operating temperature range	-40°C bis/to +80°C	-30°C bis/to +80°C	-40°C bis/to +80°C
Symbol	1	2	1
Rückschlagventil Anschluß 2 Check-Valve at Port 2	0,6 bar	-	0,5 bar

Einbaumaße / Installation:

464 007 001 0

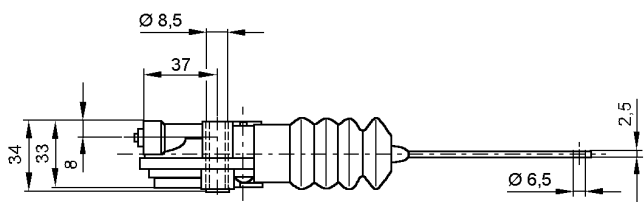
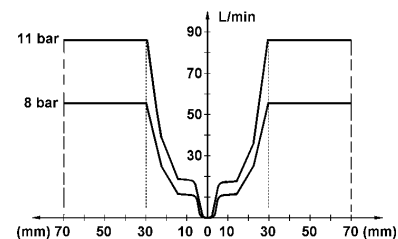
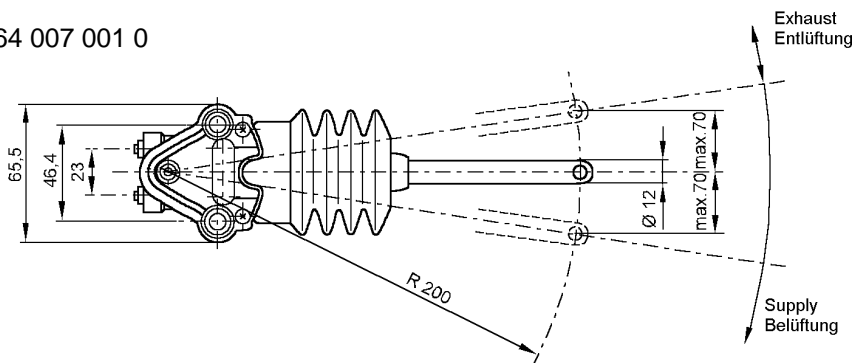

Anschlüsse / Ports:

- 1 = Ø 6 Energiezufuß
Energy supply
- 2 = Ø 6 Energieabfuß
Energy delivery

Luftfedervertil

Levelling Valve

464 007

464 007 009 0

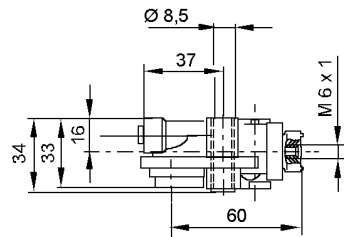
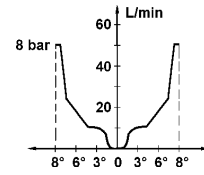
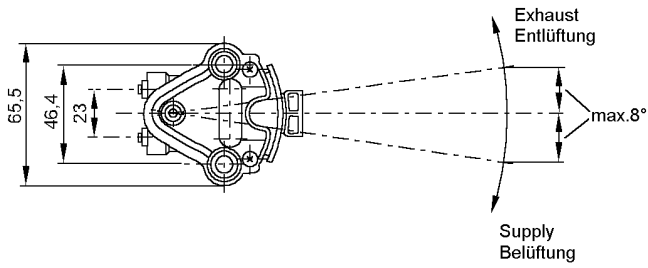

Anschlüsse / Ports:

- 1 = Ø 6 Energiezufuß
Energy supply
- 2 = Ø 6 Energieabfuß
Energy delivery

464 007 011 0

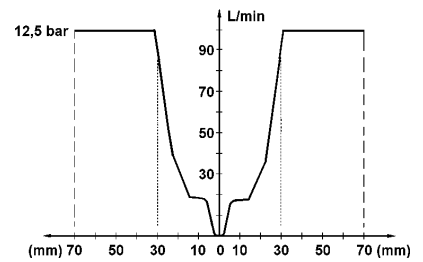
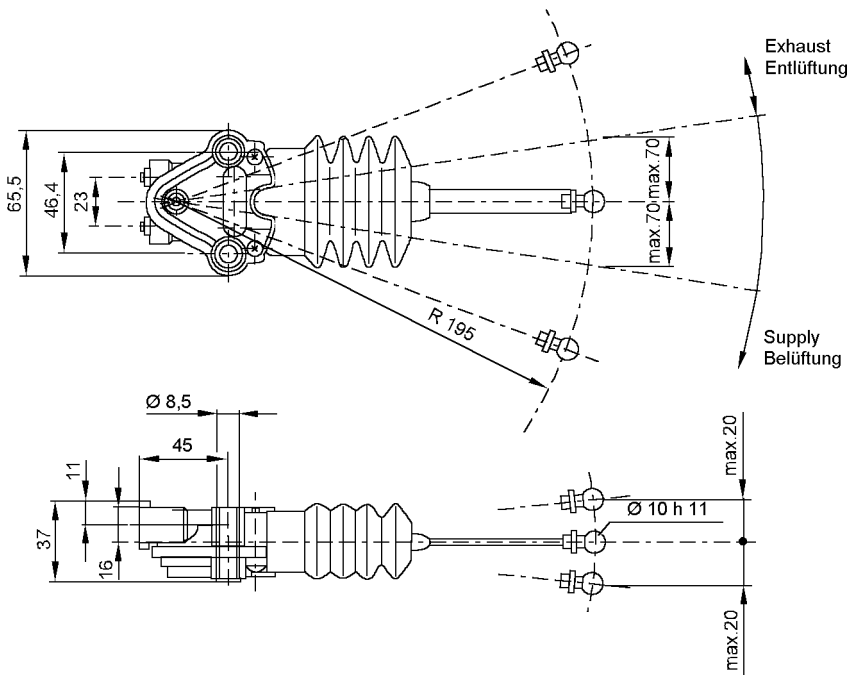

Anschlüsse / Ports:

- 1 = M 10x1 Energiezufuß
Energy supply
- 2 = M 10x1 Energieabfuß
Energy delivery