

Motorwagen-Bremsventil

Brake Valve

461 324

Teil 1 / Part 1

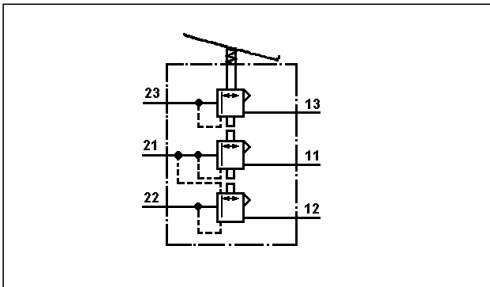

Technische Daten / Technical Data:	
Betriebsdruck Operating pressure	max. 10 bar
Zulässiges Medium Permissible medium	Luft / air
Therm. Anwendungsbereich Operating temperature range	-40°C bis/to +80°C
Nennweite Nominal diameter	Ø 10 mm
Voreilung (fest eingestellt) Predominance (fixed setting)	siehe Tabelle see table

Einbaumaße / Installation:

Kraft $F_{max.}$ bei dem erforderlichen Gesamtweg "s" = 440 N
 Force $F_{max.}$ at necessary total way "s" = 440 N

Zweck:

Feinfühliges Be- und Entlüften der Zweikreis-Motorwagen-Betriebsbremsanlage, sowie pneumatische Steuerung des Retarders über das integrierte Druckregelventil.

Einbauempfehlung:

Das trittplattenbetätigte Bremsventil ist so am Boden des Fahrerhauses anzuordnen, daß eine bequeme Beätigung der Trittplatte aus dem Fußgelenk gewährleistet ist. Der Übergang vom Fahrpedal zur Trittplatte sollte ohne Anheben des Fußes möglich sein. Die Befestigung erfolgt mit der Trägerplatte und Schrauben M8.

Purpose:

Sensitive increase and decrease of the air pressure in the towing vehicle's dual circuit service braking system and pneumatic control of the retarder via the integral pressure control valve.

Installation Requirement:

The brake valve with pedal should be installed on the floor of the cab such that comfortable operation of the pedal is ensured using the ankle. Passage from the accelerator pedal to the brake pedal should be possible without lifting the foot. The valve is fixed with carrier plate and screws M8.

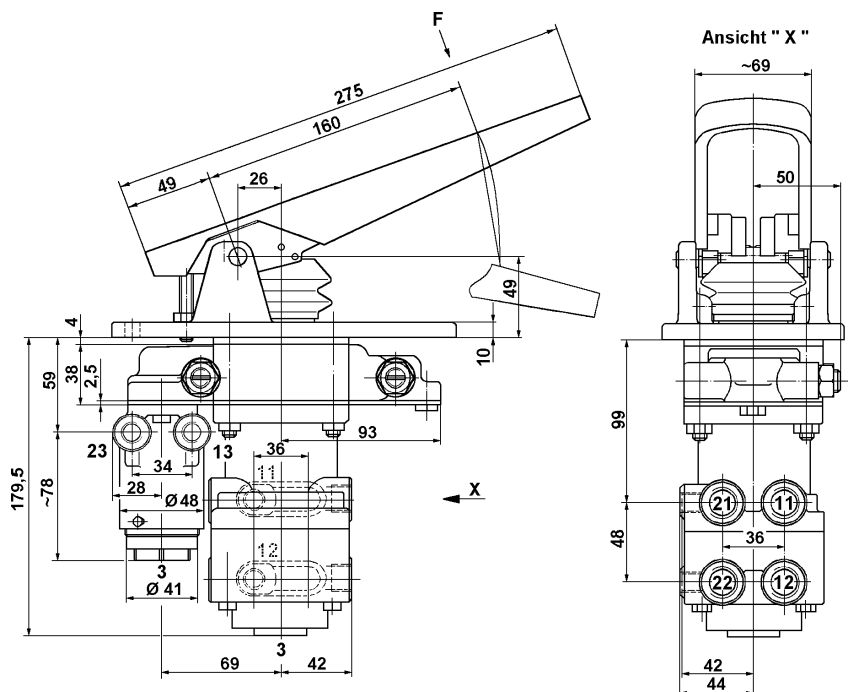

Anschlüsse / Ports:

- 11, 12 = M 16x1,5 Energiezufuß / Energy supply
- 11, 12 = M 12x1,5 Manometer, Energiezufuß
Gauge, Energy supply
- 21, 22 = M 16x1,5 Energieabfuß / Energy delivery
- 13, 23 = M 12x1,5 Druckregelventil
Pressure control valve

3

Motorwagen-Bremsventil

Brake Valve

461 324

Teil 1 / Part 1

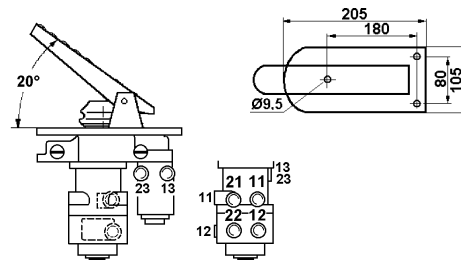
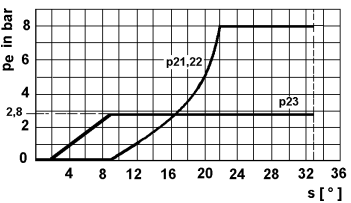
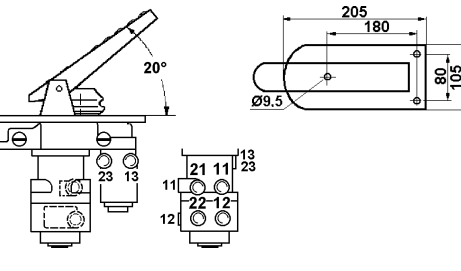
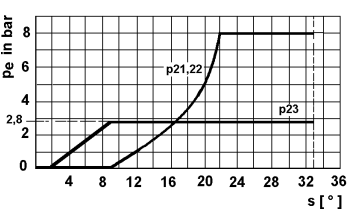
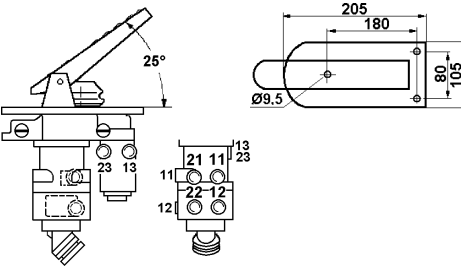
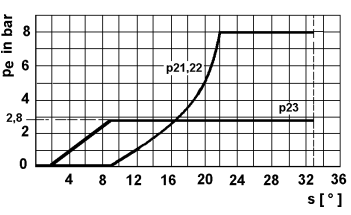
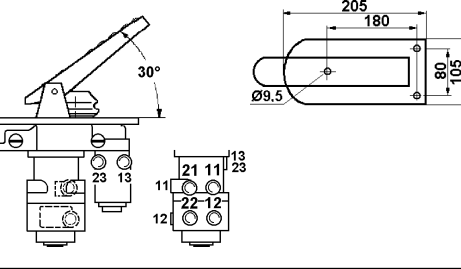
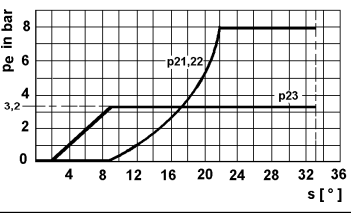
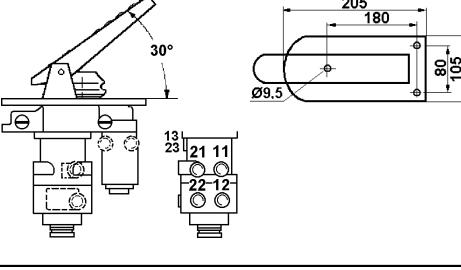
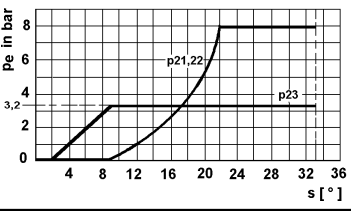
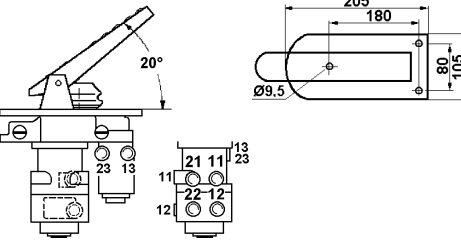
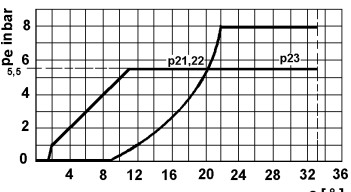
Bestellnummer / Part Number	<p>A= Basisventil / Basic valve B= Druckregelventil / Pressure control valve C= Betätigung / Operating assy</p>	Charakteristik / Characteristic	Bemerkungen Comments
461 324 001 0 A= 461 315 497 0 B= 461 324 520 0 C= 461 324 790 2		$\Delta p = \text{fest / fixed } 0,3 \text{ bar}$ 	
461 324 008 0 A= 461 315 495 0 B= 461 324 520 0 C= 461 324 790 2		$\Delta p = \text{fest / fixed } 0,3 \text{ bar}$ 	
461 324 009 0 A= 461 315 083 0 B= 461 324 520 0 C= 461 324 791 2		$\Delta p = \text{fest / fixed } 0,2 \text{ bar}$ 	
461 324 016 0 A= 461 315 497 0 B= 461 324 520 0 C= 461 324 795 2		$\Delta p = \text{fest / fixed } 0,3 \text{ bar}$ 	
461 324 018 0 A= 461 315 479 0 B= 461 324 520 0 C= 461 324 795 2		$\Delta p = \text{fest / fixed } 0 \text{ bar}$ 	
461 324 019 0 A= 461 315 497 0 B= 461 324 521 0 C= 461 324 790 2		$\Delta p = \text{fest / fixed } 0,3 \text{ bar}$ 	

Motorwagen-Bremsventil

Brake Valve

461 324
Teil 1 / Part 1

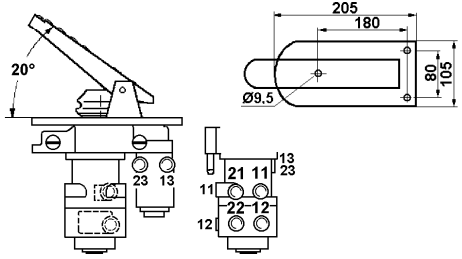
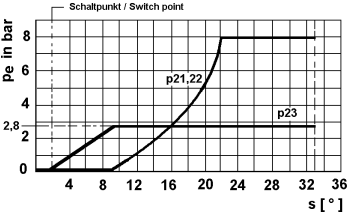
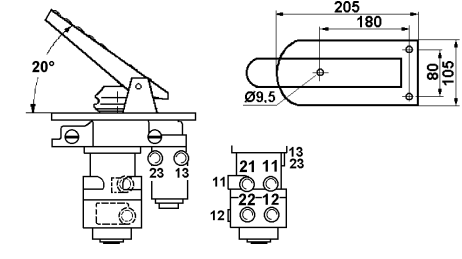
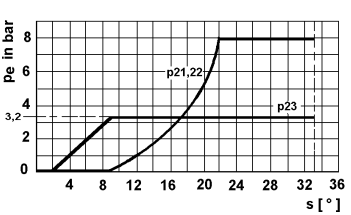
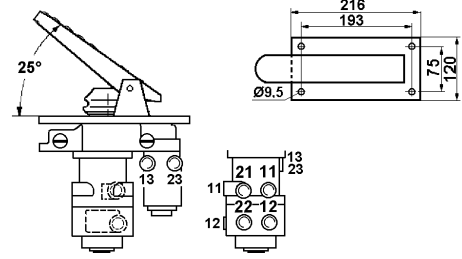
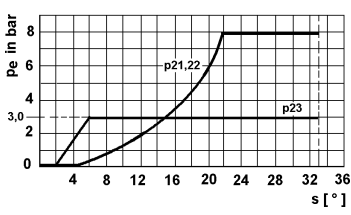
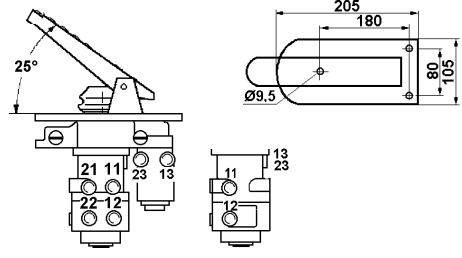
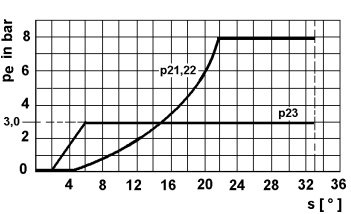
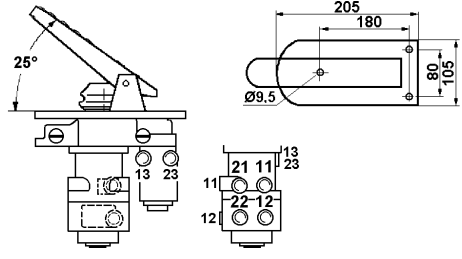
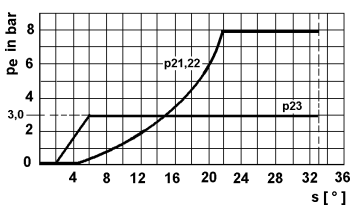
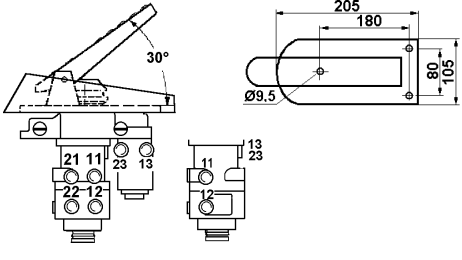
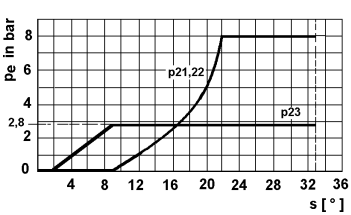
Bestellnummer / Part Number A= Basisventil / Basic valve B= Druckregelventil / Pressure control valve C= Betätigung / Operating assy		Charakteristik / Characteristic	Bemerkungen Comments
461 324 022 0 A= 461 315 463 0 B= 461 324 520 0 C= 461 324 796 2		$\Delta p = \text{fest} / \text{fixed } 0,3 \text{ bar}$ 	mit elektrischem Schalter with electrical switch
461 324 028 0 A= 461 315 497 0 B= 461 324 520 0 C= 461 324 790 2		$\Delta p = \text{fest} / \text{fixed } 0,3 \text{ bar}$ 	
461 324 031 0 A= 461 315 047 0 B= 461 324 522 0 C= 461 324 797 2		$\Delta p = \text{fest} / \text{fixed } 0 \text{ bar}$ 	
461 324 034 0 A= 461 315 048 0 B= 461 324 520 0 C= 461 324 791 2		$\Delta p = \text{fest} / \text{fixed } 0,3 \text{ bar}$ 	
461 324 039 0 A= 461 315 068 0 B= 461 324 522 0 C= 461 324 791 2		$\Delta p = \text{fest} / \text{fixed } 0 \text{ bar}$ 	
461 324 040 0 A= 461 315 152 0 B= 461 324 526 0 C= 461 324 792 2		$\Delta p = \text{fest} / \text{fixed } 0,3 \text{ bar}$ 	mit spezieller Befestigung with special fastening

3

Motorwagen-Bremsventil

Brake Valve

461 324

Teil 1 / Part 1

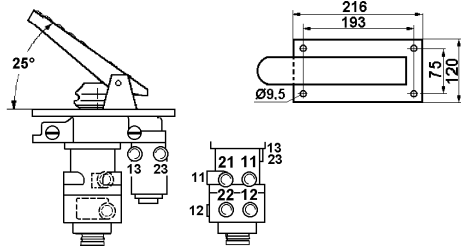
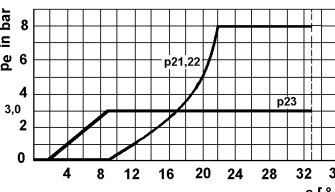
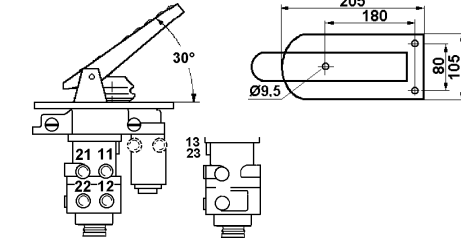
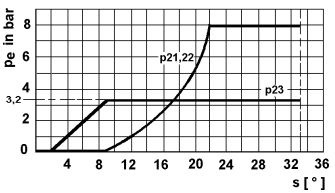
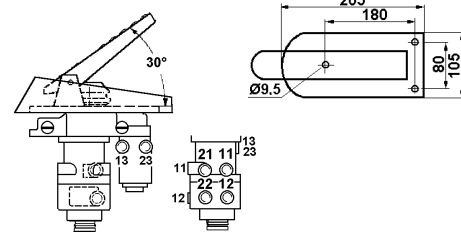
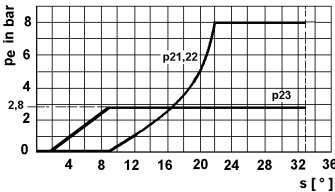
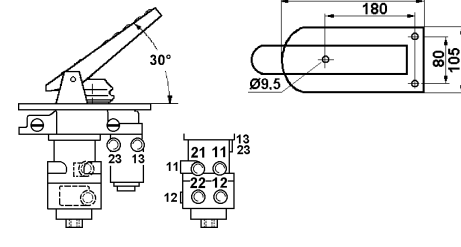
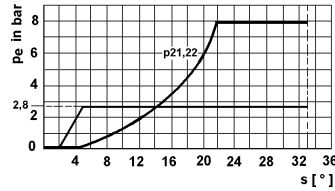
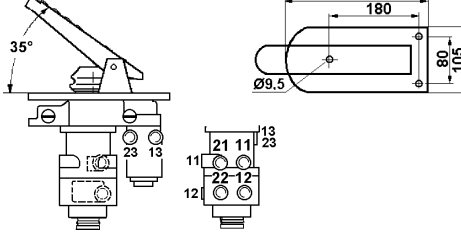
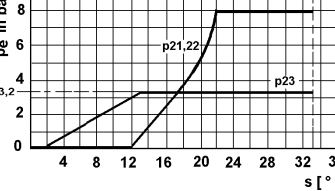
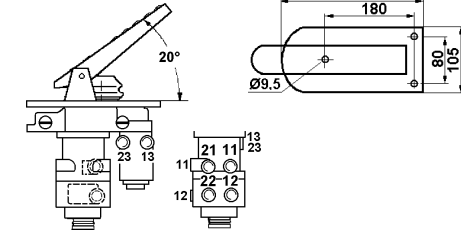
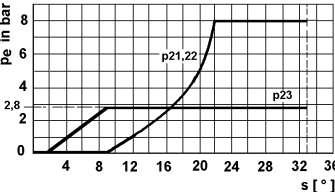
Bestellnummer / Part Number	<p>A= Basisventil / Basic valve B= Druckregelventil / Pressure control valve C= Betätigung / Operating assy</p>	Charakteristik / Characteristic	Bemerkungen Comments
461 324 041 0 A= 461 315 467 0 B= 461 324 520 0 C= 461 324 792 2		$\Delta p = \text{fest / fixed } 0,3 \text{ bar}$ 	
461 324 042 0 A= 461 315 479 0 B= 461 324 520 0 C= 461 324 795 2		$\Delta p = \text{fest / fixed } 0 \text{ bar}$ 	
461 324 043 0 A= 461 315 153 0 B= 461 324 526 0 C= 461 324 792 2		$\Delta p = \text{fest / fixed } 0,3 \text{ bar}$ 	
461 324 044 0 A= 461 315 058 0 B= 461 324 522 0 C= 461 324 792 2		$\Delta p = \text{fest / fixed } 0,3 \text{ bar}$ 	Anschluß 3 / Port 3 = M 22x1,5
461 324 045 0 A= 461 315 489 0 B= 461 324 520 0 C= 461 324 793 2		$\Delta p = \text{fest / fixed } 0,3 \text{ bar}$ 	
461 324 046 0 A= 461 315 459 0 B= 461 324 520 0 C= 461 324 790 2		$\Delta p = \text{fest / fixed } 0 \text{ bar}$ 	

Motorwagen-Bremsventil

Brake Valve

461 324

Teil 1 / Part 1

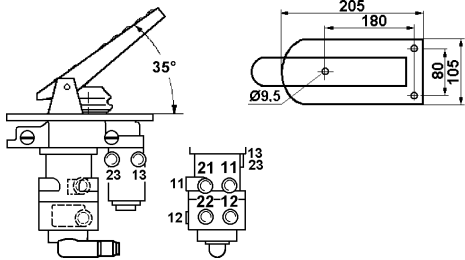
Bestellnummer / Part Number		Charakteristik / Characteristic	Bemerkungen / Comments
<p>461 324 048 0</p> <p>A= 461 315 455 0 B= 461 324 520 0 C= 461 324 793 2</p>		<p>$\Delta p = \text{fest} / \text{fixed } 0,3 \text{ bar}$</p> 