

Motorwagen-Bremsventil

Brake Valve

461 315



461 315 008 0

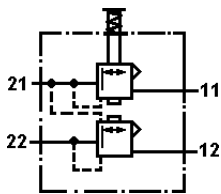

Technische Daten / Technical Data:

Betriebsdruck Operating pressure	max. 10 bar
Zulässiges Medium Permissible medium	Luft / air
Therm. Anwendungsbereich Operating temperature range	-40°C bis/to +80°C
Nennweite Nominal diameter	Ø 10 mm
Voreilung (fest eingestellt) Predominance (fixed setting)	siehe Tabelle see table

Einbaumaße / Installation:

Type A

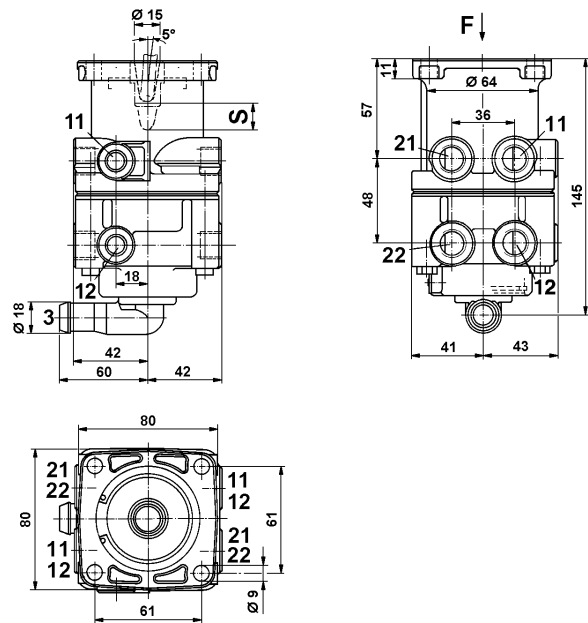

Type B

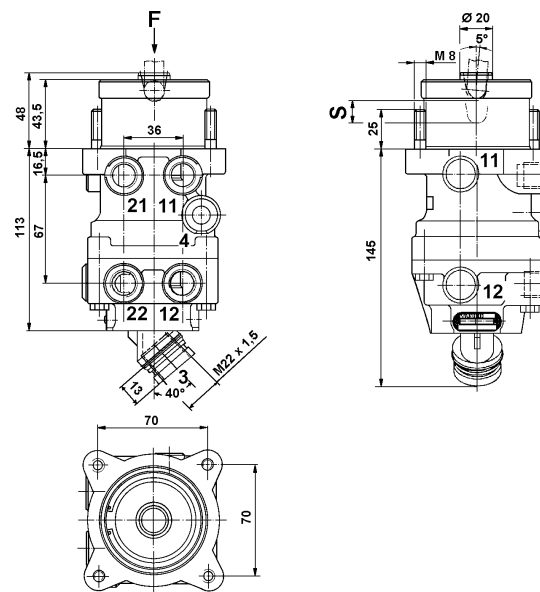

Zweck:

Feinfühliges Be- und Entlüften der Zwei-kreis-Motorwagen-Betriebsbremsanlage.

Einbauempfehlung:

Die Betätigungseinrichtung für das Motorwagen-Bremsventil ist so auszulegen, daß der Gesamtweg am Ventil durchfahren werden kann, da er beim Ausfall des 1. Kreises für die Betätigung des 2. Kreises benötigt wird. Die Befestigung erfolgt an dem dafür vorgesehenen Flansch mit Schrauben.

Purpose:

Sensitive actuation of the dual circuit truck during brake application and release service brake system.

Installation Requirement:

The design of the pedal control, acting on seat, must guarantee the maximum way of the push rod that is necessary to control the valve even in case of failure in the circuit I. Mounting is accomplished using the flange provided and screws.

3

Motorwagen-Bremsventil

Brake Valve

461 315

Einbaumaße / Installation:

Type C

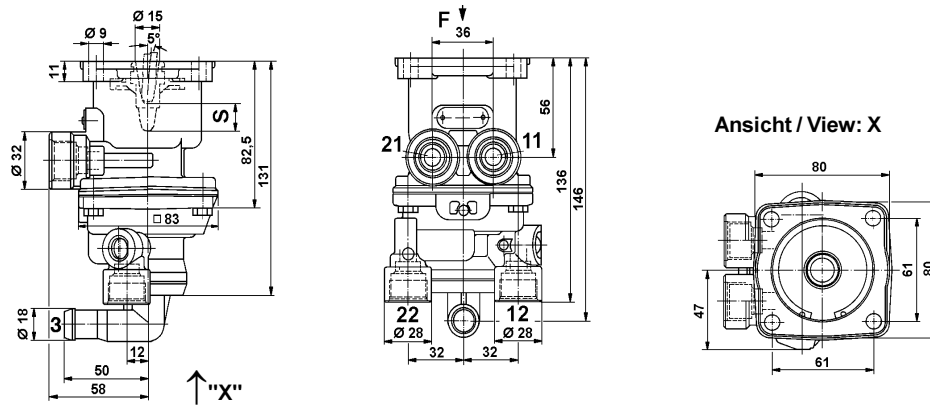

Type D

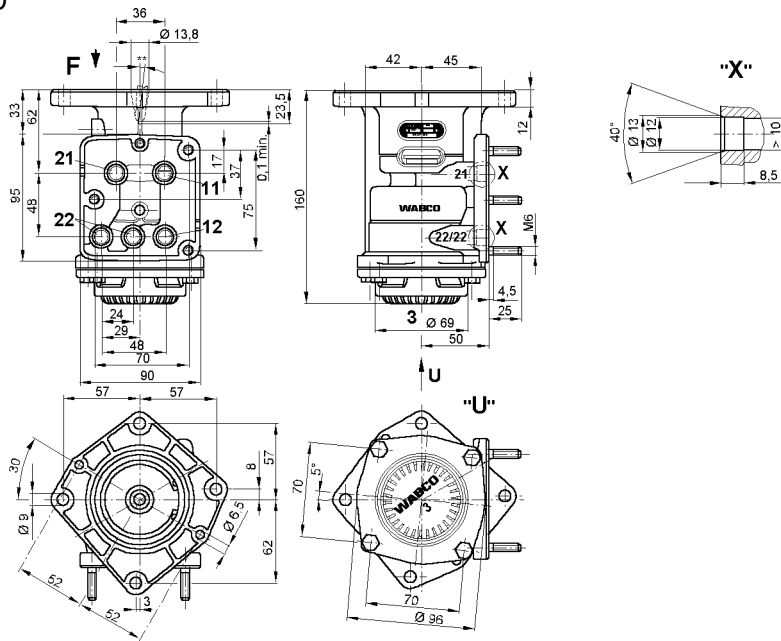

Bestellnummer Part Number	Lage der Anschlüsse Position of ports	Type	Stößelweg Way of plunger	Voreilung Predominance Δp	Anschlüsse Ports	Bemerkungen Comments
461 315 004 0		A	15,1	0,3	4x M 16x1,5 2x M 12x1,5	
461 315 008 0		A	15,1	0,3	8x M 16x1,5	

Motorwagen-Bremsventil

Brake Valve

461 315

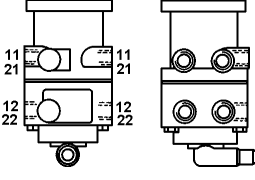
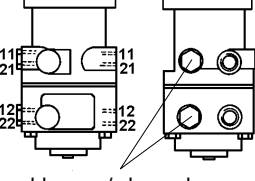
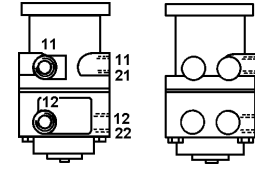
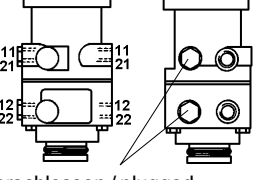
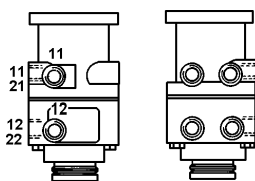
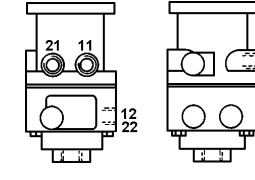
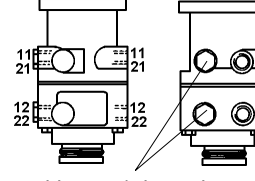
Bestellnummer Part Number	Lage der Anschlüsse Position of ports	Type	Stößelweg Way of plunger $\Delta \rho$	Voreilung Predominance $\Delta \rho$	Anschlüsse Ports	Bemerkungen Comments
461 315 009 0		A	15,1	0	8x M 16x1,5	
461 315 012 0		A	14	0,3	8x M 16x1,5	Anschluß 11,12 mit Sieb Anschluß 21,22 je 1x verschlossen; Port 11,12 with strainer Port 21,22 one each plugged
461 315 017 0		A	14	0	4x M 16x1,5 2x M 12x1,5	Anschluß 11,12 mit Sieb Anschluß 21,22 je 1x verschlossen; Port 11,12 with strainer Port 21,22 one each plugged
461 315 019 0		A	14	0	8x M 16x1,5	Anschluß 11,12 mit Sieb Anschluß 21,22 je 1x verschlossen; Port 11,12 with strainer Port 21,22 one each plugged
461 315 021 0		A	14	0	4x M 16x1,5 2x M 12x1,5	Anschluß 11,12 mit Sieb Port 11,12 with strainer
461 315 023 0		A	14	0,3	4x M 16x1,5	Anschluß 3 / Port 3 = M 22x1,5
461 315 026 0		A	14	0,4	8x M 16x1,5	Anschluß 11,12 mit Sieb Anschluß 21,22 je 1x verschlossen; Port 11,12 with strainer Port 21,22 one each plugged

3

Motorwagen-Bremsventil

Brake Valve

461 315

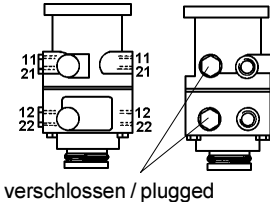
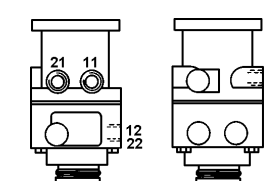
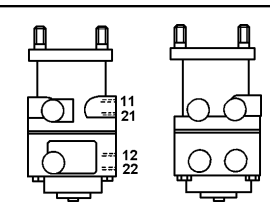
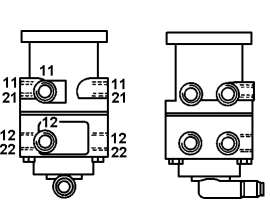
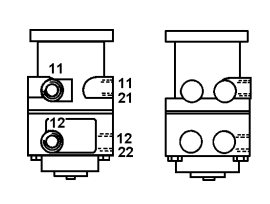
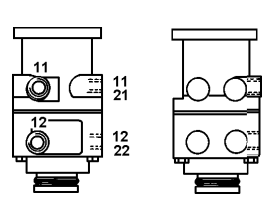
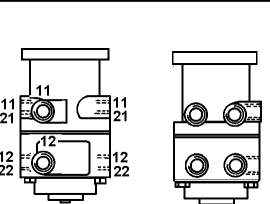
Bestellnummer Part Number	Lage der Anschlüsse Position of ports	Type	Stößelweg Way of plunger Δp	Voreilung Predominance Δp	Anschlüsse Ports	Bemerkungen Comments
461 315 027 0	 <p>verschlossen / plugged</p>	A	14	0,4	8x M 16x1,5	Anschluß 11,12 mit Sieb Anschluß 21,22 je 1x verschlossen; Port 11,12 with strainer Port 21,22 one each plugged
461 315 030 0		A	15,1	0,2	4x M 16x1,5	
461 315 036 0		A	14	0,3	4x M 16x1,5	
461 315 042 0		A	14	0	8x M 16x1,5 2x M 12x1,5	
461 315 061 0		A	14	0,3	4x M 16x1,5 2x M 12x1,5	
461 315 063 0		A	14	0,3	4x M 16x1,5 2x M 12x1,5	
461 315 064 0		A	14	0,3	8x M 16x1,5 2x M 12x1,5	

Motorwagen-Bremsventil

461 315

Brake Valve

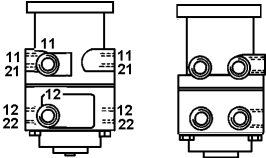
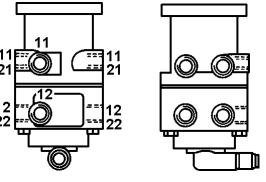
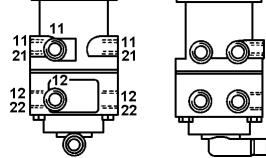
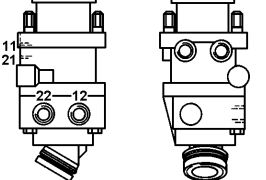
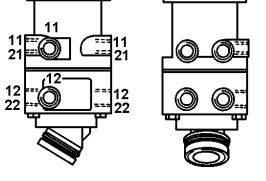
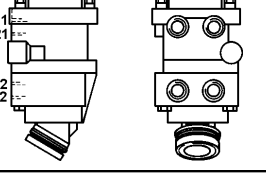
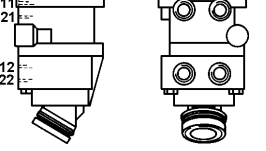
Bestellnummer Part Number	Lage der Anschlüsse Position of ports	Type	Stößelweg Way of plunger	Voreilung Predominance Δp	Anschlüsse Ports	Bemerkungen Comments
461 315 065 0		A	12	0,3	8x M 16x1,5 2x M 12x1,5	
461 315 076 0		A	15,1		4x M 16x1,5	Anschluß 3 mit integriertem Geräuschkämpfer Port 3 with integrated silencer
461 315 077 0		A	15,1		8x M 16x1,5 2x M 12x1,5	
461 315 081 0		B	14	0,5	4x M 16x1,5	Anschluß 3: mit M 22x1,5 innen Port 3: with M 22x1,5 internal
461 315 086 0		A	14	0	8x M 16x1,5 2x M 12x1,5	Anschluß 3: mit M 22x1,5 innen Port 3: with M 22x1,5 internal
461 315 088 0		B	14	0,5	4x M 16x1,5	Anschluß 3: mit M 22x1,5 innen Port 3: with M 22x1,5 internal
461 315 089 0		B	14	0	4x M 16x1,5	Anschluß 3: mit M 22x1,5 innen Port 3: with M 22x1,5 internal

3

Motorwagen-Bremsventil

Brake Valve

461 315

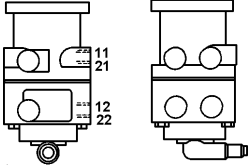
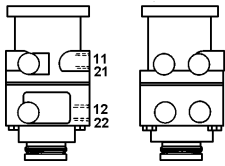
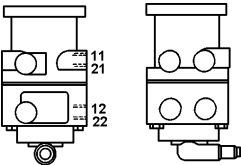
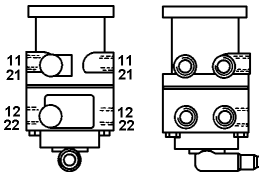
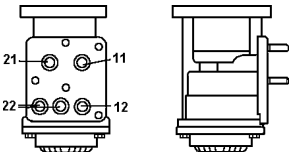
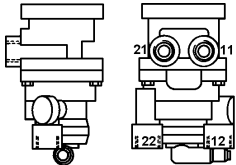
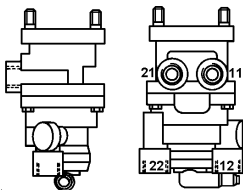
Bestellnummer Part Number	Lage der Anschlüsse Position of ports	Type	Stößelweg Way of plunger Δp	Voreilung Predominance	Anschlüsse Ports	Bemerkungen Comments
461 315 150 0		A	15,1	0,3	4x M 16x1,5	Anschluß 11,12 mit Sieb Port 11,12 with strainer
461 315 154 0		A	15,1		4x M 16x1,5	
461 315 155 0		A	12		4x M 16x1,5	
461 315 161 0		A	15,1	0,3	8x 3/8" NPTF	
461 315 180 0		D	14	0	Flansch mit Flange with 5x Ø12	Anschluß 3 mit integriertem Geräuschdämpfer Port 3 with integrated silencer
461 315 254 0		C	15,1	0,5	4x M 22x1,5 Voss	
461 315 258 0		C	15,1	0,4	4x M 22x1,5 Voss	

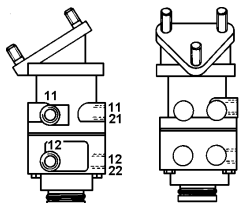
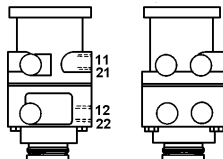
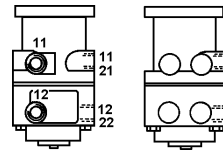
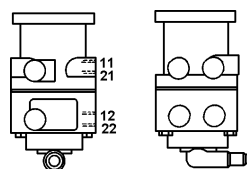
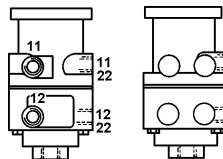
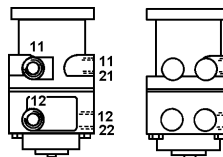
Bestellnummer Part Number	Lage der Anschlüsse Position of ports	Type	Stößelweg Way of plunger	Voreilung Predominance Δp	Anschlüsse Ports	Bemerkungen Comments
461 315 474 0		A	14	0,4	4x M 16x1,5 2x M 12x1,5	Anschluß 11,12 mit Sieb Port 11,12 with strainer
461 315 479 0		A	14	0	4x M 16x1,5	
461 315 482 0		A	14	0	4x M 16x1,5 2x M 12x1,5	Anschluß 11,12 mit Sieb Port 11,12 with strainer
461 315 491 0		A	15,1	0,5	4x M 16x1,5	
461 315 495 0		A	14	0,3	4x M 16x1,5 2x M 12x1,5	Anschluß 3 / Port 3 = M 22x1,5
461 315 497 0		A	14	0,3	4x M 16x1,5 2x M 12x1,5	