

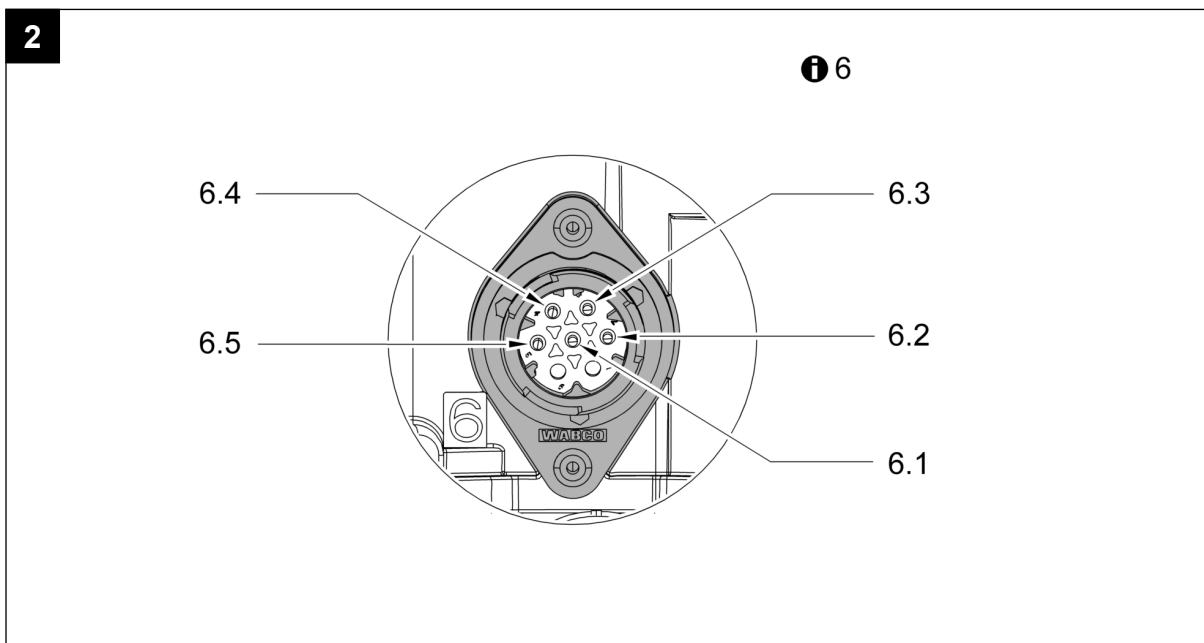

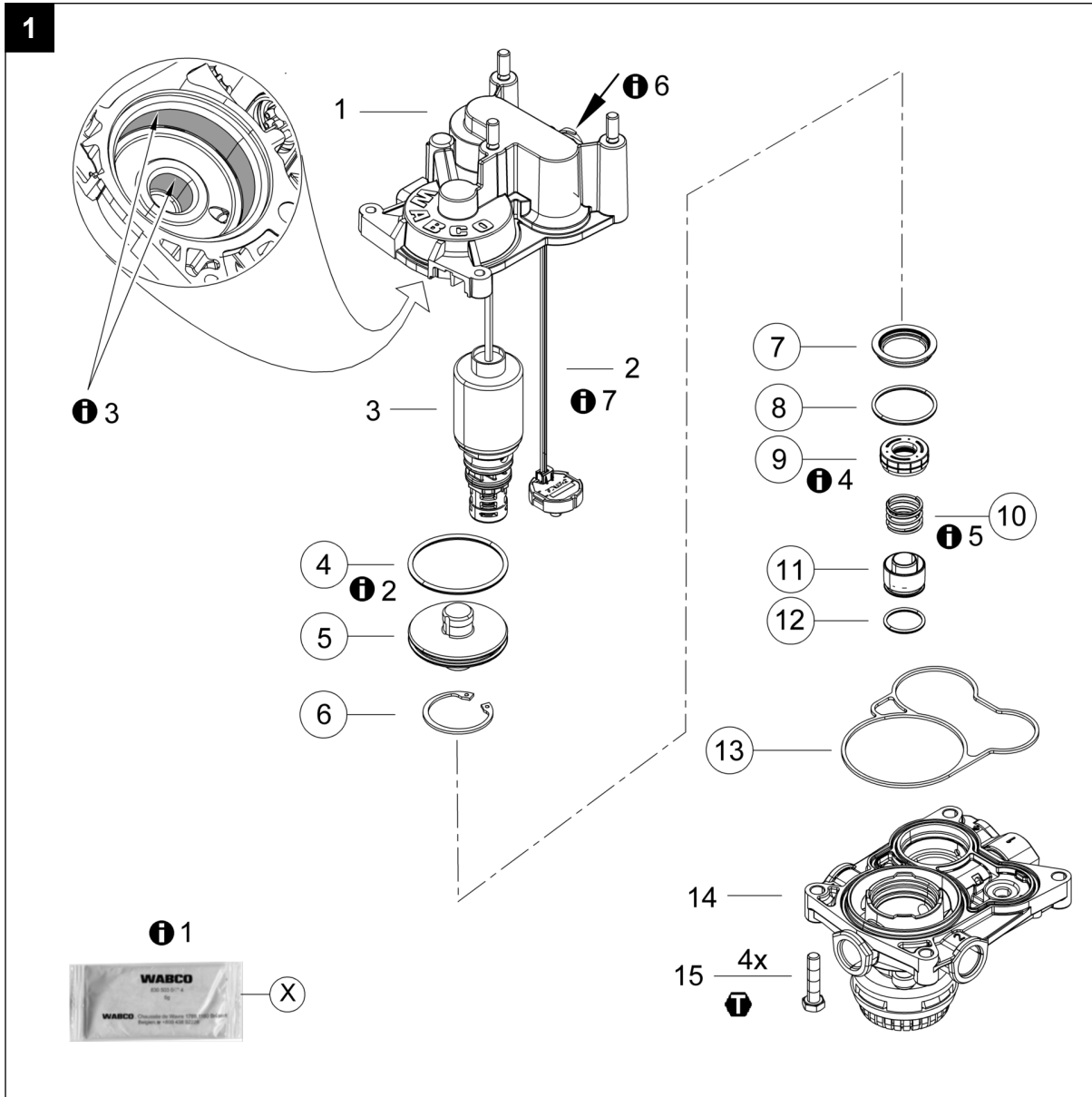







480 202 004 0
 480 202 005 0
 480 202 008 0
 480 202 009 0
 480 202 010 0
 480 202 012 0
 480 202 200 0











Signální slova a symboly



-  **DANGER** NEBEZPEČÍ Bezprostředně hrozící nebezpečí: těžká újma na zdraví nebo smrt
-  **WARNING** POZOR Možná nebezpečná situace: jako následek lehká nebo středně těžká újma na zdraví nebo poškození majetku
-  **CAUTION** VÝSTRAHA Možná nebezpečná situace: jako následek těžká újma na zdraví nebo smrt
-  Díly, které mají číslo pozice v kroužku, jsou obsažené v opravárenské sadě.

-  Instrukce / informace ke správnému provedení opravy
-  Opravárenskou sadu je možné použít pro přístroje uvedené v tabulce.
-  Součástku utáhněte uvedeným momentem.
-  Zacházení s touto komponentou vyžaduje ochranu proti elektrostatickému výboji (ESD).

Všeobecné pokyny k opravám

1. Opravárenské práce na přístrojích systému, který má vliv na bezpečnost vozidla, smí provádět pouze kvalifikovaný personál odborné servisní dílny.
3. Dodržujte předpisy BOZP podniku a národní předpisy.
5. S opravou začněte teprve tehdy, až všechny informace nutné pro opravu přečtete a porozumíte jim. Další potřebné dokumenty: zkušební postup, list náhradních dílů, všeobecné pokyny pro opravu a kontrolu (815 150 109 3) naleznete na internetových stránkách: www.wabco-auto.com, když v databázi INFORM zadáte produktové číslo přístroje nebo číslo dokumentu.
7. WABCO nepřebírá žádnou záruku za funkci nebo kvalitu opraveného přístroje.
2. Postupujte bezpodmínečně podle pokynů a instrukcí výrobce vozidla.
4. Používejte výhradně náhradní díly od firmy WABCO nebo díly schválené výrobcem vozidla.
6. Na adekvátním zařízení přezkoušejte – podle zkušebního postupu – každý opravený přístroj na funkčnost a těsnost.





Obrázek	Symbol	Pozice	Hodnota	Poznámky
		15	24 ± 2.5 Nm	
	 1		830 502 087 4	Namažte těsnící a kluzné plochy.GLK 112
	 2	4	830 502 087 4	Namažte tukem pouze jen uvedenou součást.GLK 112
	 3	5	830 502 087 4	Namažte horní čep a styčnou plochu ve víku krytu.GLK 112
	 4	9		Namažte obě těsnící manžety.
	 5	10		Pozor! Předepnutá pružina!
	 7	2		Kabel nesmí být sevřený!





 1+2	 6		Měření odporu	Změřen mezi	Tolerance při 20 ± 2°C
--	---	--	---------------	-------------	------------------------

			Kontakt 1	Kontakt 2		
			Odpor cívek	6.4	6.5	5 ± 0,5 Ω
			Izolační odpor	6.1	Hliníkový kryt	> 1 MΩ
			Izolační odpor	6.2	Hliníkový kryt	> 1 MΩ
			Izolační odpor	6.3	Hliníkový kryt	> 1 MΩ
			Izolační odpor	6.4	Hliníkový kryt	> 1 MΩ
			Izolační odpor	6.5	Hliníkový kryt	> 1 MΩ

de







Signalwörter & Symbole

-  **DANGER** GEFAHR Unmittelbar drohende Gefährdung: Schwere Personenschäden oder Tod
-  **WARNING** VORSICHT Mögliche Gefahrensituation: Leichte oder mittelschwere Personenschäden oder Sachschäden als Folge
-  **CAUTION** WARNUNG Mögliche Gefahrensituation: Tod oder schwere Personenschäden als Folge
-  Teile mit Kreis um die Positionsnummer sind im Reparatursatz enthalten.

-  Anweisung / Information für eine korrekte Reparatur
-  Der Reparatursatz kann für Geräte entsprechend Tabelle verwendet werden.
-  Element mit angegebenen Drehmoment anziehen.
-  Die Handhabung dieser Komponente erfordert einen Schutz gegen Elektrostatische Entladung (ESD).

Allgemeine Reparaturhinweise

1. Reparaturarbeiten an Geräten eines Fahrzeug-Sicherheitssystems darf nur qualifiziertes Personal einer Fachwerkstatt durchführen.
3. Halten Sie Unfallverhütungsvorschriften des Betriebes sowie nationale Vorschriften ein.
5. Beginnen Sie die Reparatur erst dann, wenn Sie alle Informationen, die für die Reparatur notwendig sind, gelesen und verstanden haben. Zusätzlich benötigte Dokumente: Prüfanweisung, Ersatzteilblatt, Allgemeine Reparatur- und Prüfhinweise (815 020 109 3) zu finden auf www.wabco-auto.com mittels Eingabe der Produktnummer des Gerätes bzw. Druckschriftennummer in INFORM.
7. WABCO übernimmt keinerlei Gewährleistung für die Funktion oder Qualität eines reparierten Gerätes
2. Leisten Sie den Vorgaben und Anweisungen des Fahrzeugherstellers unbedingt Folge.
4. Verwenden Sie ausschließlich von WABCO oder vom Fahrzeughersteller freigegebene Ersatzteile.
6. Prüfen Sie jedes reparierte Gerät – gemäß Prüfanweisung – an einer adäquaten Einrichtung auf Funktionstüchtigkeit und Dichtigkeit.





Bild	Symbol	Position	Wert	Bemerkungen
1		15	24 ± 2.5 Nm	
	 1		830 502 087 4	Fetten Sie die Dicht- und Gleitflächen ein.GLK 112
	 2	4	830 502 087 4	Fetten Sie ausschließlich die genannte Position ein.GLK 112
	 3	5	830 502 087 4	Fetten Sie den oberen Dorn und die Lauffläche im Gehäusedeckel ein.GLK 112
	 4	9		Fetten Sie beide Dichtlippen ein.
	 5	10		Achtung! Federvorspannung!
	 7	2		Das Kabel darf nicht eingeklemmt werden!





1+2	 6		Widerstandsmessung	Gemessen zwischen	Toleranz bei 20 ± 2°C
------------	---	--	--------------------	-------------------	-----------------------

			Kontakt 1	Kontakt 2		
			Spulenwiderstand	6.4	6.5	5 ± 0,5 Ω
			Isolationswiderstand	6.1	Aluminium-Gehäuse	> 1 MΩ
			Isolationswiderstand	6.2	Aluminium-Gehäuse	> 1 MΩ
			Isolationswiderstand	6.3	Aluminium-Gehäuse	> 1 MΩ
			Isolationswiderstand	6.4	Aluminium-Gehäuse	> 1 MΩ
			Isolationswiderstand	6.5	Aluminium-Gehäuse	> 1 MΩ

en









Symbols & Signal Words



-  **DANGER** Imminent hazard situation: serious personal injury or death as a result
-  **WARNING** Possible hazard situation: minor or moderate personal injury or material loss as a result
-  **CAUTION** Possible hazard situation: serious personal injury or death as a result
-  Parts having item numbers with circles are included in the kit.

-  Instruction / Information for a correct repair
-  The kit can be used for devices according table.
-  Fasteners must be tightened to a specific torque.
-  Handling of this component requires protection against electro static discharge (ESD)

General Repair Hints





1. Only qualified personnel of a specialist workshop are authorized to perform repair work on a vehicle's security system.
3. Keep to company's relevant accident prevention regulations and national regulations.
5. Always start repair work only when you have read and understood all information required for repair. Documents additionally needed: Test Instruction, Spare Parts List, General Repair and Test Hints (815 010 109 3) to be found on www.wabco-auto.com by entering product number of the device or the publication number in INFORM.
7. WABCO does not accept any liability or responsibility for the quality or functionality of a repaired device
2. Absolutely follow specifications and instructions of vehicle manufacturer.
4. Use only spare parts released by WABCO or vehicle manufacturer.
6. Check each repaired equipment for functional efficiency and tightness on an adequate facility according to the test instruction.





Picture	Symbol	Item	Value	Comments
		15	24 ± 2.5 Nm	
	 1		830 502 087 4	Lubricate sealing and sliding surfaces.GLK 112
	 2	4	830 502 087 4	Solely grease named item.GLK 112
	 3	5	830 502 087 4	Apply grease to the upper mandrel and the sliding surface in the housing cover.GLK 112
	 4	9		Apply grease to both sealing lips.
	 5	10		Attention! Spring load!
	 7	2		The cable must not be squashed!

	 6	Resistance measurement	Measured between	Tolerance at 20 ± 2°C
--	---	------------------------	------------------	-----------------------

			Contact 1	Contact 2	
		Coil resistance	6.4	6.5	5 ± 0,5 Ω
		Insulation resistance	6.1	Aluminium housing	> 1 MΩ
		Insulation resistance	6.2	Aluminium housing	> 1 MΩ
		Insulation resistance	6.3	Aluminium housing	> 1 MΩ
		Insulation resistance	6.4	Aluminium housing	> 1 MΩ
		Insulation resistance	6.5	Aluminium housing	> 1 MΩ









Símbolos & Palabras de aviso



-  **DANGER** PELIGRO Situación de peligro inminente: Pueden ocasionarse daños personales graves o incluso mortales
-  **WARNING** CUIDADO Posible situación de peligro: Pueden ocasionarse daños personales leves o moderados o pérdidas materiales
-  **CAUTION** ADVERTENCIA Posible situación de peligro: Pueden ocasionarse daños personales graves o incluso mortales
-  Los componentes incluidos en el kit son los números que aparecen con círculo.

-  Instrucciones/Información para una correcta reparación
-  El kit puede ser utilizado en los equipos que aparecen en la tabla.
-  Los cierres deben apretarse con un par de apriete determinado.
-  La manipulación de este componente requiere protección contra descargas electrostáticas (ESD)

Consejos generales de reparación

1. Sólo el personal cualificado de un taller especializado está autorizado para realizar las tareas de reparación en los sistemas de seguridad de los vehículos.
 3. Siga las regulaciones y normas acerca de prevención de riesgos laborales de su empresa y de su país.
 5. Comience la reparación sólo cuando haya leído y comprendido las instrucciones de reparación. Documentos adicionales necesarios: Instrucciones de comprobación, listas de despiece, consejos generales de comprobación y reparación (815 040 109 3), los cuales pueden encontrarse en www.wabco-auto.com, introduciendo la referencia del aparato o la referencia de la publicación en la aplicación INFORM.
 7. WABCO no asume garantía alguna por el funcionamiento o calidad de un equipo reparado.
2. Atenerse exactamente a las indicaciones e instrucciones del fabricante del vehículo.
 4. Utilice piezas de repuesto suministradas por WABCO o el fabricante del vehículo.
 6. Compruebe la eficacia de funcionamiento y de ajuste de cada equipo reparado en unas instalaciones adecuadas según las instrucciones de comprobación.





Dibujo	Símbolo	Posición	Valor	Observaciones
		15	24 ± 2.5 Nm	
	 1		830 502 087 4	Las juntas y las superficies deslizantes deben lubricarse. GLK 112
	 2	4	830 502 087 4	Engrase exclusivamente el componente indicado GLK 112
	 3	5	830 502 087 4	Engrase la espiga superior y las superficies de contacto de la tapa de la carcasa. GLK 112
	 4	9		Engrase las dos faldas de obturación.
	 5	10		¡Atención! ¡Resorte comprimido!
	 7	2		El cable no se debe aprisionar.

	 6	Medida de la resistencia	Medido entre	Tolerancia a 20 ± 2°C
--	---	--------------------------	--------------	-----------------------

			Contacto 1	Contacto 2	
		Resistencia de las bobinas	6.4	6.5	5 ± 0,5 Ω
		Resistencia de aislamiento	6.1	Carcasa de aluminio	> 1 MΩ
		Resistencia de aislamiento	6.2	Carcasa de aluminio	> 1 MΩ
		Resistencia de aislamiento	6.3	Carcasa de aluminio	> 1 MΩ
		Resistencia de aislamiento	6.4	Carcasa de aluminio	> 1 MΩ
		Resistencia de aislamiento	6.5	Carcasa de aluminio	> 1 MΩ

fr

Symboles & Significations

-  **DANGER** DANGER Situation de danger imminent : Danger de mort ou de dommage corporel sérieux.
-  **WARNING** ATTENTION Situation de danger probable : Risque de dommage corporel mineur ou modéré ou perte de matériel.
-  **CAUTION** AVERTISSEMENT Situation de danger de danger probable : Danger de mort ou de dommages corporel sérieux
-  Les composants avec repères entourés sont inclus dans le kit.

 Instruction/Information pour une réparation correcte









 Le kit peut être utilisé pour les appareils indiqués sur le Feuille.

 Les fixations doivent être serrées à un couple spécifique.

 La manipulation de cette composante nécessite une protection contre les décharges électro statiques (ESD)

Conseils généraux de réparation

1. Uniquement le personnel qualifié d'un atelier agréé WABCO est autorisé à effectuer la réparation sur les systèmes de sécurité d'un véhicule.
3. Veillez aux règlements de prévention des accidents indiqués par votre société et aux règlements nationaux.
5. Commencez toujours le travail de réparation seulement après avoir lu et compris toutes les informations indiquées pour la réparation. Documentation complémentaire nécessaire : Instruction d'essai, liste des pièces détachées, instructions de réparation et conseils d'essai (815 030 109 3) en tapant la référence du produit ou le numéro de la publication dans INFORM sur internet : www.wabco-auto.com
7. WABCO n'assume aucune garantie quant au fonctionnement ou à la qualité d'un appareil réparé.
2. Respecter toujours les prescriptions et instructions du constructeur du véhicule.
4. Employez seulement les pièces de rechange WABCO ou du constructeur du véhicule.
6. Examinez chaque appareil réparé pour s'assurer de l'efficacité fonctionnelle et de l'étanchéité selon l'instruction d'essai.





Image	Symbole	Position	Valeur	Remarques
		15	24 ± 2.5 Nm	
	 1		830 502 087 4	Les surfaces d'étanchéité et de frottement doivent être graissées. GLK 112
	 2	4	830 502 087 4	Graisser cette pièce. GLK 112
	 3	5	830 502 087 4	Lubrifier le mandrin supérieur et la surface de roulement dans le couvercle du carter. GLK 112
	 4	9		Lubrifier les deux lèvres d'étanchéité.
	 5	10		Attention! Ressort comprimé!
	 7	2		Faire attention de ne pas coincer le câble !





	 6		Mesure de la résistance	Mesurée entre	Tolérance à 20 ± 2°C
--	---	--	-------------------------	---------------	----------------------

			Contact 1	Contact 2	
		Résistance de bobine	6.4	6.5	5 ± 0,5 Ω
		Résistance d'isolement	6.1	Boîtier en aluminium	> 1 MΩ
		Résistance d'isolement	6.2	Boîtier en aluminium	> 1 MΩ
		Résistance d'isolement	6.3	Boîtier en aluminium	> 1 MΩ
		Résistance d'isolement	6.4	Boîtier en aluminium	> 1 MΩ
		Résistance d'isolement	6.5	Boîtier en aluminium	> 1 MΩ

hr









Simboli & Značenja



-  **DANGER** OPREZ Neposredna rizična situacija: moguće ozbiljno ozljeđivanje ili smrt
-  **WARNING** OPASNOST neposredna rizična situacija: moguće manje ozljeđivanje materijalna šteta
-  **CAUTION** UPOZORENJE Neposredna rizična situacija: moguće ozbiljno ozljeđivanje ili smrt
-  Dijelovi uređaja čiji su brojevi zaokruženi nalaze se u kompletu..

-  Informacija o ispravnom popravku.
-  Set može biti korišten za uređaje prema tabeli.
-  Spone moraju biti stegnute prema specifičnim silama zatezanja.
-  Rukovanje ovim uređajem zahtjeva zaštitu od elektro statičkog pražnjenja

Opće upute o popravcima





1. Samo kvalificirane osobe istručnjaci smiju popravljati sigurnosne sustave na vozilu.
3. Provodi tvrtkine sigurnosne propise kao i nacionalne propise o sigurnosti
5. Popravak počni tek nakon što pročitaš i shvatiš upute o popravku. Potrebni dokumenti: Instrukcije o testiranju, Lista rezervnih dijelova, Opće natuknice o popravku i testiranju (815 010 109 3) mogu se naći na www.wabco-auto.com nakon upisa kataloškog broja proizvoda ili publikacije u INFORM-u.
7. WABCO ne preuzima odgovornost za rad i kvalitetu popravljenog uređaja.
2. U potpunosti slijedi specifikacije i upute proizvođača vozila.
4. Koristi rezervne dijelove proizvedene od WABCA ili proizvođača vozila..
6. Provjeri svaki popravljeni uređaj kako radi i da li je zategnuto sve kako treba prema odgovarajućim uputama o testiranju proizvoda.





Slika	Simbol	Pojednost	Vrijednost	Komentar
		15	24 ± 2.5 Nm	
	 1		830 502 087 4	Brtvne i klizne površine treba podmazati.GLK 112
	 2	4	830 502 087 4	Lagano podmazati samo ovaj dio.GLK 112
	 3	5	830 502 087 4	Namastite gornji trn i hodnu površinu poklopca kućišta.GLK 112
	 4	9		Namastite obje brtvene usne.
	 5	10		Pažnja! Opruga pod opterećenjem!
	 7	2		Kabel ne smije biti zaglavljen!

	 6	Mjerenje otpora	Izmjereno između	Odstupanje pri 20 ± 2°C
--	---	-----------------	------------------	-------------------------

			Kontakt 1	Kontakt 2	
		Otpor svitka	6.4	6.5	5 ± 0,5 Ω
		Otpor izolacije	6.1	Aluminijsko kućište	> 1 MΩ
		Otpor izolacije	6.2	Aluminijsko kućište	> 1 MΩ
		Otpor izolacije	6.3	Aluminijsko kućište	> 1 MΩ
		Otpor izolacije	6.4	Aluminijsko kućište	> 1 MΩ
		Otpor izolacije	6.5	Aluminijsko kućište	> 1 MΩ







Simboli e Segnali

-  **DANGER** PERICOLO Imminente situazione di rischio: serie ferite personali fino anche alle morte
-  **WARNING** PRUDENZA Possibili situazioni di pericolo: possibili lievi ferite o perdita di materiale
-  **CAUTION** AVVERTENZA Possibili situazioni di pericolo: serie ferite personali fino anche alle morte
-  I componenti indicati con un numero cerchiato, sono inclusi nel kit.

-  Istruzioni/Informazioni per unacorretta riparazione
-  Il kit può essere usato per gli articoli secondo la tabella.
-  I fissaggi devono essere stretti ad una coppia di serraggio specifica.
-  L'impiego di questi componenti richiede una protezione da scariche elettrostatiche (ESD).

Suggerimenti per la riparazione

1. Soltanto il personale qualificato delle officine specializzate è autorizzato ad effettuare le riparazioni sui sistemi di sicurezza dei veicoli.
3. Attenersi alle norme nazionali e aziendali in merito alla prevenzione degli infortuni.
5. Effettuare la riparazione solamente dopo aver letto e capito tutte le informazioni richieste per la riparazione. Ulteriori informazioni necessarie: istruzioni di collaudo, catalogo dei ricambi, cenni generali sulla riparazione e test (815 050 109 3) possono essere trovati sul sito www.wabco-auto.com alla voce INFORM entrando per codice del dell'apparecchio o per numero della pubblicazione.
7. WABCO non si assume alcuna responsabilità per il funzionamento o la qualità di un apparecchio riparato.
2. E' assolutamente necessario seguire le istruzioni e le specifiche del costruttore del veicolo.
4. Usare solo ricambi originali WABCO o del costruttore del veicolo.
6. Controllare la funzionalità e l'efficienza di ogni apparecchiatura riparata secondo le istruzioni riportate nel manuale di collaudo.





Figura	Simbolo	Particolare	Valore	Note
1		15	24 ± 2.5 Nm	
	 1		830 502 087 4	Superfici di tenuta e di scorrimento devono essere lubrificate. GLK 112
	 2	4	830 502 087 4	Ingrassare esclusivamente la suddetta posizione. GLK 112
	 3	5	830 502 087 4	Ingrassare la punta superiore e la superficie di scorrimento nel coperchio della scatola. GLK 112
	 4	9		Ingrassare i due labbri di tenuta.
	 5	10		Attenzione! Molla compressa!
	 7	2		Il cavo non deve essere bloccato!

1+2	 6		Misurazione della resistenza	Misurare tra	Tolleranza di 20 ± 2°C
------------	---	--	------------------------------	--------------	------------------------

			Contatto 1	Contatto 2		
			Resistenza della bobina	6.4	6.5	5 ± 0,5 Ω
			Resistenza di isolamento	6.1	Alloggiamento in alluminio	> 1 MΩ
			Resistenza di isolamento	6.2	Alloggiamento in alluminio	> 1 MΩ
			Resistenza di isolamento	6.3	Alloggiamento in alluminio	> 1 MΩ
			Resistenza di isolamento	6.4	Alloggiamento in alluminio	> 1 MΩ
			Resistenza di isolamento	6.5	Alloggiamento in alluminio	> 1 MΩ

pl

Hasła ostrzegawcze i symbole

-  **DANGER** NIEBEZPIECZEŃSTWO Bezpośrednie zagrożenie ciężkimi obrażeniami bądź śmiercią.
-  **WARNING** UWAGA! Niebezpieczeństwo grożące lekkimi bądź średnimi obrażeniami.
-  **CAUTION** OSTRZEŻENIE Niebezpieczeństwo grożące śmiercią bądź ciężkimi obrażeniami.
-  Części oznaczone kółkiem wokół numeru pozycji należą do zestawu naprawczego.

 Wskazówki / Informacje dotyczące poprawnej naprawy.









 Zestaw naprawczy może być używany do urządzeń według tabeli.

 Dokręcić element podanym momentem obrotowym.

 Obsługa tego komponentu wymaga ochrony przed wyładowaniami elektrostatycznymi (ESD).

Ogólne porady naprawcze

1. Prace naprawcze w obrębie urządzeń układu bezpieczeństwa pojazdu mogą być wykonane jedynie przez wykwalifikowany personel specjalistycznego warsztatu.
3. Należy przestrzegać zakładowych i krajowych przepisów BHP.
5. Naprawę należy rozpocząć dopiero wówczas, gdy wszystkie potrzebne do niej informacje zostaną przeczytane i zrozumiane. Dokumenty potrzebne dodatkowo: instrukcja kontrolna, tabela części zamiennych, ogólne wskazówki dotyczące naprawy i kontroli (815 020 109 3) znajdują Państwo na stronie internetowej www.wabco-auto.com, podając numer urządzenia bądź numer publikacji w bazie INFORM.
7. WABCO nie udziela żadnej gwarancji na działanie lub jakość naprawionego urządzenia.
2. Należy koniecznie postępować według wytycznych i wskazówek producenta pojazdu.
4. Należy używać wyłącznie części zamiennych dopuszczonych przez firmę WABCO bądź przez producenta pojazdu.
6. Na odpowiednim urządzeniu należy sprawdzić każde naprawiane urządzenie - zgodnie z instrukcją kontrolną - pod kątem sprawności działania i szczelności.





Obraz	Symbol	Pozycja	Wartość	Komentarz
		15	24 ± 2.5 Nm	
	 1		830 502 087 4	Należy nasmarować powierzchnie uszczelniające i ślizgowe.GLK 112
	 2	4	830 502 087 4	Użyj smaru do zaznaczonych elementów.GLK 112
	 3	5	830 502 087 4	Nasmarować górny trzpień i powierzchnię bieżną w pokrywie obudowy.GLK 112
	 4	9		Nasmarować obie uszczelki wargowe.
	 5	10		Uwaga! Sprężyna!
	 7	2		Kabel nie może zostać zakleszczony!





1+2	 6		Pomiar rezystancji	Zmierzone pomiędzy	Tolerancja przy 20 ± 2°C
------------	---	--	--------------------	--------------------	--------------------------

			Styk 1	Styk 2		
			Rezystancja cewki	6.4	6.5	5 ± 0,5 Ω
			Rezystancja izolacji	6.1	Obudowa aluminiowa	> 1 MΩ
			Rezystancja izolacji	6.2	Obudowa aluminiowa	> 1 MΩ
			Rezystancja izolacji	6.3	Obudowa aluminiowa	> 1 MΩ
			Rezystancja izolacji	6.4	Obudowa aluminiowa	> 1 MΩ
			Rezystancja izolacji	6.5	Obudowa aluminiowa	> 1 MΩ

ru









Знаки & символы

-  **DANGER** ОПАСНО Прямая угроза аварийной ситуации: влечет за собой смерть или тяжелые повреждения
-  **WARNING** ОСТОРОЖНО Опасная ситуация: последствиями являются легкие повреждения или повреждения средней тяжести, а также материальный ущерб
-  **CAUTION** ПРЕДУПРЕЖДЕНИЕ Опасная ситуация: влечет за собой смерть или тяжелые повреждения
-  Номера частей, обведенные кружком, Вы найдете в ремкомплекте.

-  Указание/информация для проведения надлежащего ремонта
-  Ремкомплект может быть использован для приборов соответственно таблице.
-  Элемент необходимо подтянуть с помощью заданного момента сопротивления.
-  При обращении с данным устройством необходимо обеспечить защиту от образования электростатического разряда

Общие указания по ремонту

1. Провождение ремонта приборов данной системы должно производиться только квалифицированным персоналом в специализированной мастерской.
3. Соблюдайте предписания предприятия по технике безопасности, а также национальные нормы.
5. Проводите ремонт только после того, как вы прочитали и поняли все информации, необходимые для данного процесса. Дополнительные документы: инструкция по тестированию, список запасных частей, общие инструкции по ремонту и проведению испытаний (815 080 109 3) Вы найдете на www.wabco-auto.com. Для этого необходимо задать номер нужного прибора или номер брошюры в INFORM.
7. Компания WABCO не принимает на себя какую-либо ответственность за работу или качество отремонтированных устройств.
2. Следуйте предписаниям и инструкциям изготовителя транспортного средства.
4. Используйте только запчасти, допущенные к использованию компанией Wabco или производителем транспортного средства.
6. Проконтролируйте каждый отремонтированный прибор- согласно инструкции по тестированию- на работоспособность и герметичность с помощью соответствующего оборудования.





Изображение	Символ	Позиция	Значение	Замечания
		15	24 ± 2.5 Nm	
	 1		830 502 087 4	Смажьте поверхности уплотнения / скольжения. GLK 112
	 2	4	830 502 087 4	Смажьте названную часть. GLK 112
	 3	5	830 502 087 4	Смазать пластичной смазкой верхнюю оправку и рабочую поверхность в крышке корпуса. GLK 112
	 4	9		Смазать обе рабочие кромки уплотнения пластичной смазкой.
	 5	10		Внимание! Натянутая пружина!
	 7	2		Провод нельзя зажимать!





1+2	 6		Измерение сопротивления	Измерено между	Допуск при 20 ± 2°C
------------	---	--	-------------------------	----------------	---------------------

			Контакт 1	Контакт 2	
		Сопротивление катушки	6.4	6.5	5 ± 0,5 Ω
		Сопротивление изоляции	6.1	Алюминиевый корпус	> 1 MΩ
		Сопротивление изоляции	6.2	Алюминиевый корпус	> 1 MΩ
		Сопротивление изоляции	6.3	Алюминиевый корпус	> 1 MΩ
		Сопротивление изоляции	6.4	Алюминиевый корпус	> 1 MΩ
		Сопротивление изоляции	6.5	Алюминиевый корпус	> 1 MΩ

SV







Signalord & symboler



-  **DANGER** FARA Omedelbar risk: svåra personskador eller dödsfall
-  **WARNING** VARNING Möjlig risk: Lätta eller medelsvåra personskador eller materiella skador
-  **CAUTION** VARNING Möjlig risksituation: Dödsfall eller svåra personskador
-  Delar med inringat positionsnummer ingår i reparationssetsen.

-  Anvisningar/information för korrekt reparation
-  Reparationssetsen kan användas för apparater enligt tabellen.
-  Dra åt elementet med angivet åtdragningsmoment.
-  Vid hantering av dessa komponenter krävs skydd mot elektrostatisk urladdning (ESD).

Allmänna reparationsanvisningar

1. Reparationsarbeten på enheter i fordonssäkerhetssystem får endast genomföras av kvalificerad personal på behörig verkstad.
3. Följ alltid företagets föreskrifter för förebyggande av olycksfall samt gällande nationella föreskrifter.
5. Börja inte med reparationsarbetena förrän du har läst igenom och förstått all nödvändig information. Nödvändiga extradokument: Kontrollanvisning, reservdelsblad, allmän reparation och kontrollinformation (815 070 109 3). Du hittar dokumenten på www.wabco-auto.com genom att mata in apparatens produktnummer eller dokumentnummer i INFORM.
7. WABCO ansvarar inte för reparerade enheters funktion eller kvalitet.
2. Beakta alltid fordonstillverkarens specifikationer och anvisningar.
4. Används endast reservdelar som är godkända av WABCO eller fordonstillverkaren.
6. Varje reparerad apparat ska kontrolleras på funktionsduglighet och täthet på en lämplig anordning enligt kontrollanvisningen.



Bild	Symbol	Position	Värde	Kommentar
		15	24 ± 2.5 Nm	
	 1		830 502 087 4	Smörj tättnings- och glidytor. GLK 112
	 2	4	830 502 087 4	Smörj in endast den angivna positionen. GLK 112
	 3	5	830 502 087 4	Smörj det övre dornet och löpytan i husets lock med fett. GLK 112
	 4	9		Smörj de båda läpptätningarna med fett.
	 5	10		Observera! Fjäderförspänning!
	 7	2		Kabeln får inte hamna i kläm!



 1+2	 6	Motståndsmätning	Mätt mellan	Tolerans vid 20 ± 2°C
--	---	------------------	-------------	-----------------------

			Kontakt 1	Kontakt 2	
		Lindningsresistans	6.4	6.5	5 ± 0,5 Ω
		Isoleringsmotstånd	6.1	Aluminiumhus	> 1 MΩ
		Isoleringsmotstånd	6.2	Aluminiumhus	> 1 MΩ
		Isoleringsmotstånd	6.3	Aluminiumhus	> 1 MΩ
		Isoleringsmotstånd	6.4	Aluminiumhus	> 1 MΩ
		Isoleringsmotstånd	6.5	Aluminiumhus	> 1 MΩ

el

Προειδοποιητικές λέξεις & Σύμβολα

-  **DANGER** ΚΙΝΔΥΝΟΣ! Άμεσα επαπειλούμενος κίνδυνος: Σοβαρές σωματικές βλάβες ή θάνατος
-  **WARNING** ΠΡΟΣΟΧΗ! Πιθανή επικίνδυνη κατάσταση: Ελαφρές ή μεσαίας έκτασης σωματικές βλάβες ή υλικές βλάβες
-  **CAUTION** ΠΡΟΕΙΔΟΠΟΙΗΣΗ! Πιθανή επικίνδυνη κατάσταση: Θάνατος ή σοβαρές σωματικές βλάβες

-  Οδηγίες / πληροφορίες για την ορθή επισκευή
-  Το kit επισκευής μπορεί να χρησιμοποιηθεί για συσκευές αναλόγως του πίνακα.
-  Συσφίξτε το στοιχείο με την ενδεικτική ροπή στρέψης.

el

Γενικές υποδείξεις επισκευής

- Εργασίες επισκευής σε συσκευές ενός συστήματος ασφαλείας οχημάτων επιτρέπονται μόνο από εκπαιδευμένο εξειδικευμένο προσωπικό ειδικού συνεργείου.
- Τηρείτε τους κανονισμούς πρόληψης ατυχημάτων της επιχείρησης, καθώς και τις εθνικές διατάξεις.
- Ξεκινάτε την επισκευή μόνο αφού έχετε αναγνώσει και κατανοήσει όλες τις πληροφορίες που είναι απαραίτητες για την επισκευή. Επιπροσθέτως απαιτούμενα έγγραφα: Οδηγίες ελέγχου, Φύλλο ανταλλακτικών, Γενικές υποδείξεις επισκευής και ελέγχου (815 200 109 3), θα τα βρείτε στη σελίδα www.wabco-auto.com, εισάγοντας τον κωδικό προϊόντος της συσκευής και/ή τον αριθμό του εντύπου στον κατάλογο προϊόντων INFORM.
- Η WABCO δεν φέρει καμία ευθύνη για τη λειτουργία ή την ποιότητα μίας επισκευασμένης συσκευής.
- Τηρείτε οπωσδήποτε τις οδηγίες και τις επισημάνσεις του κατασκευαστή του οχήματος.
- Χρησιμοποιείτε αποκλειστικά ανταλλακτικά της WABCO ή του κατασκευαστή του οχήματος.
- Ελέγχετε τη λειτουργικότητα και στεγανότητα κάθε επισκευασμένης συσκευής - σύμφωνα με τις οδηγίες ελέγχου - σε μια κατάλληλη διάταξη.

Εικόνα	Σύμβολο	Θέση	Τιμή	Παρατηρήσεις
		15	24 ± 2.5 Nm	
	1		830 502 087 4	Λιπάνετε τις επιφάνειες στεγανοποίησης και ολίσθησης.GLK 112
	2	4	830 502 087 4	Λιπάνετε αποκλειστικά την αναφερόμενη θέση.GLK 112
	3	5	830 502 087 4	Λαδώστε τον επάνω σφινγκτήρα και την επιφάνεια κύλισης στο κάλυμμα του περιβλήματος.GLK 112
	4	9		Λαδώστε και τα δύο στεγανοποιητικά χείλη.
	5	10		Προσοχή! Προένταση ελατηρίου!
	7	2		Το καλώδιο δεν πρέπει να πιάνεται!

1+2	6	Μέτρηση αντίστασης	Μέτρηση μεταξύ	Ανοχή στους 20 ± 2°C
-----	---	--------------------	----------------	----------------------

			Επαφή 1	Επαφή 2	
		Αντίσταση πηνίου	6.4	6.5	5 ± 0,5 Ω
		Αντίσταση μόνωσης	6.1	Περιβλήμα αλουμινίου	> 1 MΩ
		Αντίσταση μόνωσης	6.2	Περιβλήμα αλουμινίου	> 1 MΩ
		Αντίσταση μόνωσης	6.3	Περιβλήμα αλουμινίου	> 1 MΩ
		Αντίσταση μόνωσης	6.4	Περιβλήμα αλουμινίου	> 1 MΩ
		Αντίσταση μόνωσης	6.5	Περιβλήμα αλουμινίου	> 1 MΩ

tr

Semboller&belirti sözleri

- DANGER** TEHLİKE Tehlikeli durum: ciddi personel yaralanması veya ölüm riski.
- WARNING** DİKKAT Tehlike riski: hafif personel yaralanması veya maddi zarar.
- CAUTION** UYARI Ciddi personel yaralanması veya ölüm riski.
- Yuvarlak içinde numarası belirtilen parça numaraları kit içerisinde bulunur.

- Talimat/ Doğru tamir için bilgi
- Tabloda belirtilen parçalar için kit kullanılabilir.
- Vidalar özel tork değerine kadar sıkılmalıdır.
- Bu bileşenle çalışmalarda elektrostatik deşarja (ESD'ye) karşı bir koruma kesinlikle gereklidir.

tr

Genel tamir bilgisi

- Araçların güvenlik sistemlerinde tamir işlemlerini yalnızca eğitim almış konusunda uzman personeller gerçekleştirebilir.
- Araç üretici firma özellikler ve talimatlarına kesinlikle uyunuz.
- Şirket emniyet kuralları ve ulusal regülasyonlarına uyunuz.
- Sadece WABCO veya üretici firma tarafından yayınlanan yedek parçaları kullanın.
- Tamir edilmiş her cihazı - test talimatına uygun şekilde - uygun bir donanımla işlevsellik ve sızdırmazlık konusunda kontrol edin.
- WABCO tamir edilmiş bir cihazın işlevselliği veya kalitesi için hiçbir sorumluluk üstlenmemektedir.

Resim	Sembol	Parça	Değer	Yorumlar
		15	24 ± 2.5 Nm	
		1	830 502 087 4	Conta ve sürtünme ile çalışan yüzeyler yağlanmalıdır.GLK 112
		2	830 502 087 4	Yalnızca belirtilen pozisyonu gresleyin.GLK 112
		3	830 502 087 4	Üstteki mandreli ve gövde içindeki hareket yüzeyini gresleyin.GLK 112
		4	9	Her iki dudak tipi sızdırmazlık elemanını gresleyin.
		5	10	Dikkat! Yay yükü!
		7	2	Kablo sıkıştırılmamalıdır!

1+2		6	Direnç ölçümü	Ölçüm noktaları	Belirtilen değerdeki tolerans
					20 ± 2°C

			Kontak 1	Kontak 2		
			Bobin direnci	6.4	6.5	5 ± 0,5 Ω
			İzolasyon direnci	6.1	Alüminyum kasa	> 1 MΩ
			İzolasyon direnci	6.2	Alüminyum kasa	> 1 MΩ
			İzolasyon direnci	6.3	Alüminyum kasa	> 1 MΩ
			İzolasyon direnci	6.4	Alüminyum kasa	> 1 MΩ
			İzolasyon direnci	6.5	Alüminyum kasa	> 1 MΩ

pt

Símbolos e Significados







- DANGER** Perigo! Risco de acidente iminente: lesão corporal grave e/ou risco de morte.
- WARNING** Cuidado! Possível situação de acidente: ferimentos leves/moderados e/ou danos materiais.
- CAUTION** Atenção! Possível situação de acidente: lesão corporal grave e/ou risco de morte.
- Componentes que estão marcados com um círculo compõem o jogo de reparo.

- Instrução/Informação para uma correta reparação.
- O jogo de reparo pode ser utilizado nos produtos relacionados na tabela.
- Parafusos/porcas devem ser montados de acordo com o torque especificado.
- Antes do passo de trabalho seguinte, certifique-se de que todos os parafusos estão apertados com o binário de aperto correto.

pt

Dicas Gerais para Reparação

1. Por motivo de segurança, somente pessoas qualificadas devem efetuar reparação nos sistemas de freio do veículo.
2. Siga sempre as recomendações/especificações do fabricante do veículo.
3. Mantenha e siga as orientações de prevenção de acidentes vigentes e/ou impostas pelos órgãos competentes.
4. Use somente peças de reposição aprovadas pela WABCO ou pelo fabricante do veículo.
5. Somente inicie o trabalho de reparação após ler e entender todas as informações necessárias para realizar uma reparação. Documentos adicionais necessários: instrução de teste, lista de peças sobressalentes, dicas gerais de testes e reparação (815 130 109 3) podem ser encontrados no site www.wabco-auto.com ao inserir o número do produto.
6. Verificar cada produto reparado conforme instruções de teste, utilizando os equipamentos necessários e local adequado.
7. A WABCO não assume qualquer responsabilidade pela função ou qualidade de um equipamento reparado.





Figura	Símbolo	Item	Valor	Comentários
1		15	24 ± 2.5 Nm	
		1	830 502 087 4	Superfícies de vedação e deslizamento devem ser lubrificadas GLK 112
		2	4	830 502 087 4 Aplicar graxa no item GLK 112
		3	5	830 502 087 4 Lubrifique o espigão superior e o apoio do rolamento na tampa da caixa. GLK 112
		4	9	Lubrifique ambos os lábios de lubrificação.
		5	10	Atenção! Mola forte!
		7	2	O cabo não pode ficar preso!





1+2		6	Medição de resistência	Medido entre	Tolerância na 20 ± 2°C
------------	---	---	------------------------	--------------	------------------------

				Contato 1	Contato 2	
			Resistência da bobina	6.4	6.5	5 ± 0,5 Ω
			Resistência de isolamento	6.1	Caixa em alumínio	> 1 MΩ
			Resistência de isolamento	6.2	Caixa em alumínio	> 1 MΩ
			Resistência de isolamento	6.3	Caixa em alumínio	> 1 MΩ
			Resistência de isolamento	6.4	Caixa em alumínio	> 1 MΩ
			Resistência de isolamento	6.5	Caixa em alumínio	> 1 MΩ

ro

Simboluri și cuvinte pentru avertizare

-  **DANGER** Situație de pericol iminentă: poate rezulta vătămare corporală gravă sau deces.
-  **WARNING** Posibilă situație de pericol: pot rezulta vătămări corporale minore sau medii sau pagube materiale
-  **CAUTION** Posibilă situație de pericol: poate rezulta vătămare corporală gravă sau deces
-  Pieșele cu numărul de articol încercuit sunt incluse în kit.

-  Instrucțiuni / Informare pentru o reparare corectă
-  Kitul poate fi folosit pentru dispozitive, conform tabelului.
-  Elementele de fixare trebuie să fie strânse la un moment specific.
-  Manipularea acestui component necesită protecție împotriva descărcărilor electro-stactice (ESD)

Instrucțiuni generale referitoare la reparație

1. Numai personalul calificat al unui atelier de service specializat este autorizat să efectueze lucrări de reparații pe sistemul de siguranță al vehiculului.
2. Respectați obligatoriu instrucțiunile date de producătorul vehiculului.
3. Respectați prevederile firmei și cele naționale pentru prevenirea accidentelor.
4. Utilizați exclusiv piese de schimb autorizate de WABCO sau de producătorul autovehiculului.
5. Întotdeauna începeți lucrările de reparații numai după ce ați citit și înțeles toate informațiile necesare pentru reparație. Documente suplimentare necesare: Instrucțiuni de testare, Lista pieselor de schimb, Instrucțiuni generale pentru reparare și testare (815 110 109 3) pot fi găsite pe www.wabco-auto.com introducând codul dispozitivului în INFORM.
6. Verifică eficiența funcțională și etanșeitatea fiecărui echipament reparat pe o instalație adecvată în conformitate cu instrucțiunile de testare.
7. WABCO nu garantează sau nu răspunde pentru funcționarea și calitatea unui dispozitiv reparat.

Imagine	Simbol	Articol	Valoare	Comentarii
1		15	24 ± 2.5 Nm	
	i 1		830 502 087 4	Suprafețele de etanșare și alunecare trebuie să fie lubrificate.GLK 112
	i 2	4	830 502 087 4	Gresați componentele indicate.GLK 112
	i 3	5	830 502 087 4	Gresați dornul superior și suprafața de rulare din capacul carcasei.GLK 112
	i 4	9		Gresați ambele garnituri de etanșare.
	i 5	10		Atenție! Arc sub tensiune!
	i 7	2		Cablul nu trebuie să fie blocat!

1+2	i 6	Măsurarea rezistenței	Măsurată între	Toleranță la 20 ± 2°C
------------	------------	-----------------------	----------------	-----------------------

			Contact 1	Contact 2	
		Rezistența bobinei	6.4	6.5	5 ± 0,5 Ω
		Rezistența de izolație	6.1	Carcasă din aluminiu	> 1 MΩ
		Rezistența de izolație	6.2	Carcasă din aluminiu	> 1 MΩ
		Rezistența de izolație	6.3	Carcasă din aluminiu	> 1 MΩ
		Rezistența de izolație	6.4	Carcasă din aluminiu	> 1 MΩ
		Rezistența de izolație	6.5	Carcasă din aluminiu	> 1 MΩ