

Reparatursatz ♦ Jeu de réparation ♦ Repair kit Corredo di riparazione ♦ Conjunto de reparación

463 039 000 2

für Geräte:
for devices:
pour appareils:
per apparecchi:
para aparatos:

463 039 000 0
002
003
005
006

○ = Les pièces sont dans la pochette
○ = Particolare contenuto nel corredo

Achtung: Reparatur nur durch autorisierte Werkstatt zugelassen!
Attention: Repair only by authorized workshop permitted!
Attention: Réparation seulement permise par les ateliers autorisés!
Attenzione: È permessa la riparazione solo agli adetti dell'officina autorizzata!
Atención: La reparación solo está permitida a talleres especializados.

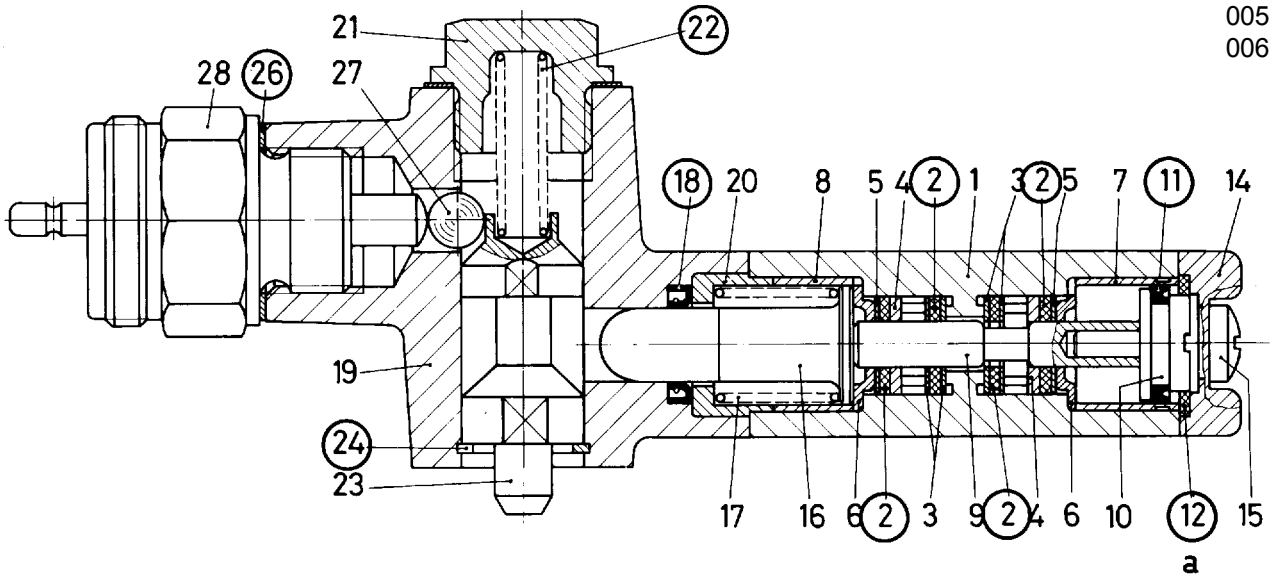

a) ☞ Zu verwenden nach Bedarf
To be used as required as occasion demands
Application suivant besoin
Applicazione secondo necessità



○ = Diese Teile sind im Reparatursatz enthalten
○ = These parts are included in the repair kit
○ = Estas piezas están incluidas en el conj. de reparación

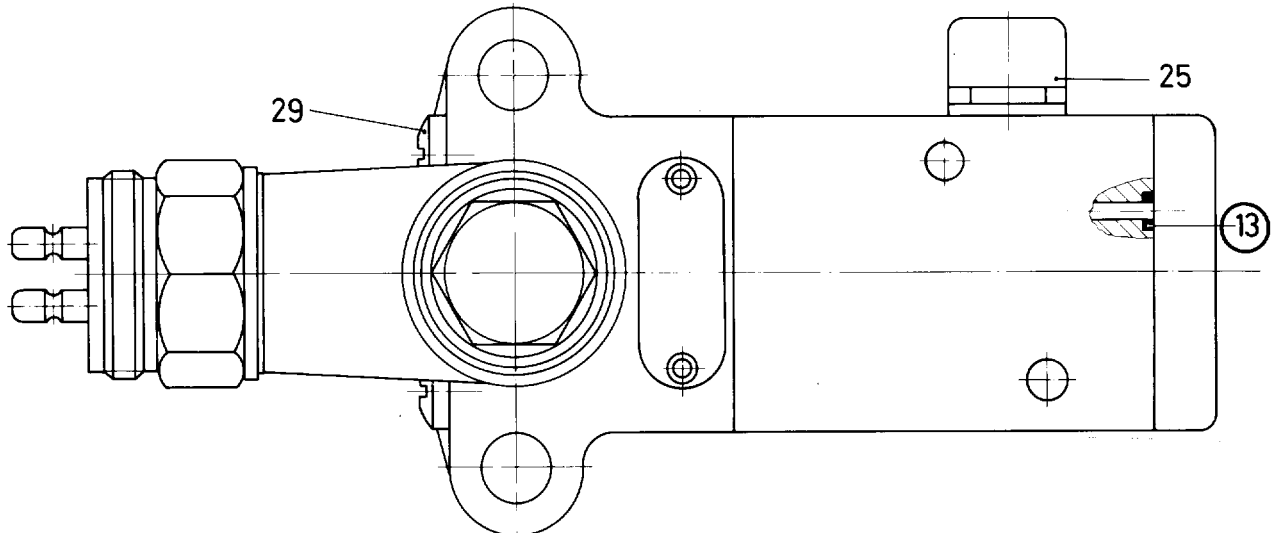

○ = Änderungen bleiben vorbehalten © Copyright: WABCO
Nachdruck - auch auszugsweise - nur mit unserer Genehmigung.
The right of amendment is reserved © copyright: WABCO
No part of this publication may be reproduced without our prior permission.
Sous toute réserve de modifications © copyright: WABCO
Toute reproduction interdite sans autorisation préalable.
Con riserva di eventuali modifiche © copyright: WABCO
Questa pubblicazione non può essere riprodotta, senza la nostra.
Reservado el derecho de modificación © copyright: WABCO
Ninguna parte de esta publicación puede reproducirse sin el consentimiento previo.

WABCO Vehicle Control Systems
An American Standard Company

826 100 296 3 Edition 09.88