

Test instruction

i Prior to testing read carefully the safety instructions.

Safety Instructions

 **WARNING**

Testing the device on the test bench is to be made only by qualified personnel with a specific system knowledge.

Always start testing only after you have read and understood all information required for testing.

Test the device only on a calibrated test bench.

In case of doubt, use test values specified by the vehicle manufacturer.

While testing the device implicitly observe this test instruction.

 **CAUTION**

Comply with internal as well as national accident prevention regulations.

Unlock screws, hoses and equipment parts only when the respective lines of the test bench are vented.

Test instruction for device 461 318 ... 0

000	006	017	026
001	007	018	028
002	009	019	030
003	014	021	047
004	015	022	049
005	016	025	070

Symbols and signal terms

 **WARNING**

Possible danger: Any non-compliance can result in severe personal injuries or death.

 **CAUTION**

Possible danger: Any non-compliance can result in minor or medium severe personal injuries.

- Handling
- Enumeration
- i** Instructions, explanations, information, tips
-  Gauge indication

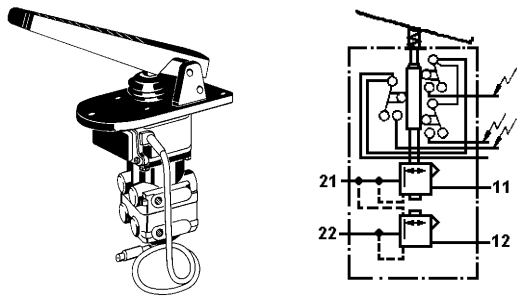

Fig. 1 + 2 Brake valve 461 318 ... 0 / Functional symbol

i **Additional documents:**
(see www.wabco-auto.com => INFORM)

- Test Values 2/2:
to be found by entry of the product number in INFORM
- Test Bench - Operating Instructions:
435 197 000 0
- General Repair and Test Hints
(i.e. 815 010 109 3 for english edition)

i **Necessary equipment/tools**

- Test bench 435 197 000 0 or an adequate testing equipment
- Adequate equipment:
 - for clamping the brake valve,
 - for actuating the pedal with degree graduation.
- 3 test lamps for checking the pass of the switches

Check sequence

- i** Perform test procedure as per specified sequence
Find test values P1 to P17 and G1 to G13 in document "Test values 2/2".
Reservoir pressure is 10 bar max.

! CAUTION

Before starting any test ensure that cut-off cocks are in their correct normal position (see table 1).

Cock	A	B	C	D	F	L	V	2	3	4	6	7	11	12	21	22
on	x												x		x	
off		x	x	x	x	x	x	x	x	x	x	x		x		x

Table 1: Normal position of cut-off cocks on the test bench

1. External evaluation

- Inspect device for external visible damage.
- Check all ports of the device for free passage by visual inspection.

2. Preparations

- Fix device in clamping equipment.
- Connect device to test bench ports. (see fig. 3).

Fig. 3 Test bench ports

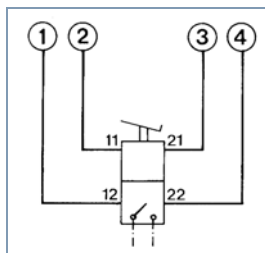

! CAUTION

Make sure that plug-in connections on test bench and device are safely plugged.

- Lock unused ports.

3. Check tightness

! WARNING

Never install an untightened brake valve on the vehicle.

3.1 Exhaust

- i** From a non-actuated device no air must exceed from the exhaust.
- Vent ports 11 and 12 with P1.
 - Gauges 1 and 2 must indicate P2.
 - Fully operate device several times.
 - Wait until excess pressure has decreased.
 - Check exhaust of the device for tightness.

i No leakages admissible.

3.2 Complete device

- Fix degree scale to the device.
- i** 0-position of the pedal means 0-position of the graduation at the same time.

- Adjust pedal to G1.
- ⌚ Gauges 3 and 4 must indicate P2.
- Cover complete device with soap and check tightness.
- i** No leakages admissible.
With soap bubbling the device is not tight.
- Re-adjust pedal to 0°.
- ⌚ Gauges 3 and 4 must indicate 0 bar.

4. Obtain maximum pressure

- Adjust pedal to G9.
- i** Pressure must increase immediately.
- ⌚ Gauges 3 and 4 must indicate P13.
- Re-adjust pedal to 0°.
- ⌚ Gauges 3 and 4 must indicate 0 bar.

5. Gradability

- i** In all pressure scopes incremental steps of max. 0.3 bar must be possible.

6. Settings

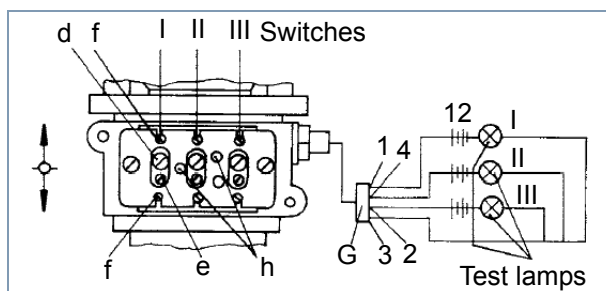

Fig. 4 Connection of the test lamps

- Operate pedal three times up to P3.
- ⌚ Gauges 3 and 4 must indicate immediate pressure increase resp. decrease.
- i** In accordance with the type of device, one circuit must have predominance.
- Adjust pedal to G2.
- ⌚ Gauges 3 and 4 must indicate P4.

6.1 Switch I, II and III

- Remove cap from the switch (see fig. 6).
- Connect test lamps.
- Release cylinder screw d (see fig. 4).
- Tighten set screw e until cut in point is reached (see fig. 4).

- Turn set screw e by about one quarter of a turn.
- Turn cylinder screw with M = 1.2 Nm (see fig. 4).
- i** Test lamps I, II and III must light up.
- Re-adjust pedal to 0°.
- ⌚ Gauges 3 and 4 must indicate 0 bar.
- i** Test lamps I, II and III must be off.

If the test lamps are still lighting up, you must act as follows:

- Release cylinder screw f of the concerning switch slightly (see fig. 4).
- Slide the switch toward the OFF direction until test lamp is off.

6.2 Switching points

Switch I

- Adjust pedal to G3.
- ⌚ Gauges 3 and 4 must indicate 0 bar.
- i** Test lamp for Switch I lights up.

If an adjustment is necessary, you must act as follows:

- Release cylinder screw f slightly.
- On the cylinder screws f (see fig. 4) move the concerning switch in direction OFF and then in direction ON until cut in point is reached.
- Tighten cylinder screw f with M = 0.6 Nm.

Switch II

- Adjust pedal to G4.
- ⌚ Gauges 3 and 4 must indicate 0 bar.
- i** Test lamp for Switch II lights up.
- i** If an adjustment is necessary, you must act as described under Switch I.

Switch III

- Adjust pedal to G5.
- ⌚ Gauge 3 must indicate P5.
Gauge 4 must indicate P6.
- Adjust pedal to G6.
- ⌚ Gauge 3 must indicate P7.
Gauge 4 must indicate P8.
- i** Test lamp for Switch III lights up.

i If an adjustment is necessary, you must act as described under Switch I.

7. Check pressure increase

7.1 Distance until venting of P9/P10

– Adjust pedal to G7.

i Pressure must increase immediately.

⊗ Gauge 3 must indicate P9.

Gauge 4 must indicate P10.

i Test lamps I, II and III must light up.

7.2 Distance until venting of P11/P12

– Adjust pedal to G8.

i Pressure must increase immediately.

⊗ Gauge 3 must indicate P11.

Gauge 4 must indicate P12.

i Test lamps I, II and III must light up.

7.3 Distance until venting of P13

– Adjust pedal to G9.

i Pressure must increase immediately.

⊗ Gauges 3 and 4 must indicate P13.

i Test lamps I, II and III must light up.

8. Switch off test lamps

8.1 Test lamp III

– Adjust pedal to G10.

⊗ Gauge 3 must indicate P14.

Gauge 4 must indicate P15.

i Test lamp III must be off.

8.2 Test lamp II

– Adjust pedal to G11.

⊗ Gauge 3 must indicate P16.

Gauge 4 must indicate P17.

i Test lamp II must be off.

8.3 Test lamp I

– Adjust pedal to G12.

⊗ Gauges 3 and 4 must indicate 0 bar.

i Test lamp I must be off.

– Insert plate 461 908 107 4 in the locating bore h (see fig. 4).

– Re-adjust pedal to 0°.

⊗ Gauges 3 and 4 must indicate 0 bar.

9. Failure of circuit 1

– Vent port 11 to 0 bar.

⊗ Gauge 1 must indicate 0 bar.

Gauge 2 must indicate P1.

– Adjust pedal to G9 (stop within device).

⊗ Gauge 3 must indicate 0 bar.

Gauge 4 must indicate P13.

i Test lamps I, II and III must light up.

– Re-adjust pedal to 0°.

⊗ Gauges 3 and 4 must indicate 0 bar.

9.1 Adjust pressure point on the pedal

– Adjust pedal to G13.

⊗ Gauges 3 and 4 must indicate 0 bar.

i Test lamps II and III must be off.

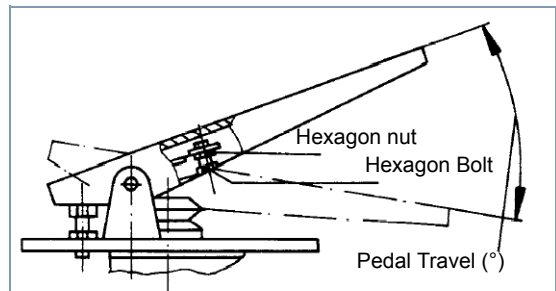

Fig. 5 Pedal

– Release hexagon nut (see fig. 5).

– Screw hexagon bolt up to the pedal and counter it with hexagon nut (M = 4 Nm), see fig. 5.

– Re-adjust pedal to 0°.

⊗ Gauges 3 and 4 must indicate 0 bar.

– Operate pedal with G13 by hand.

i The preset pressure point must be tangible at G13.

The pressure point must be between the cut in points Switch I and Switch II.

– Operate pedal with G9 (stop within the device).

⊗ Gauge 3 must indicate 0 bar.

Gauge 4 must indicate P13.

i Test lamps I, II and III must light up.

- Re-adjust pedal to 0°.
- ↻ Gauges 3 and 4 must indicate 0 bar.
- i** Test lamps I, II and III must be off.

10. Completion of test

- Vent port 12 to 0 bar.
- ↻ Gauges 1 and 2 must indicate 0 bar.

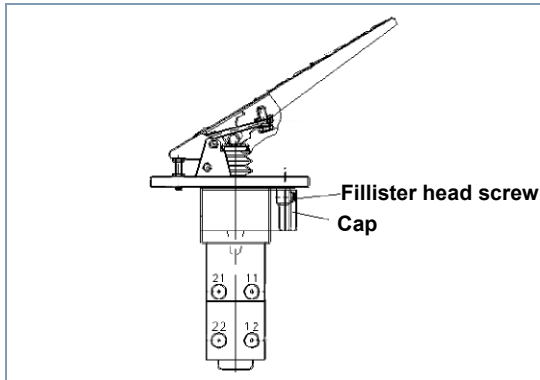

Fig. 6 Brake Valve 461 318 ... 0

- Put the cap on (see fig. 6).
- Screw fillister head screw with $M = 2.5 \text{ Nm}$ (see fig. 6).
- Check the electrical connections 1-4 within the plug casing G against ground (see fig. 4).

CAUTION

Disconnect pipe connections only after having exhausted the device to 0 bar before.

- Removing device from fixture.
- Cleaning device.