

Symbole & Signalwörter ♦ Symbols & Signal Words ♦ Symboles & Significations ♦ Simboli & Segnali Words ♦ Símbolos & Palabras de aviso

DANGER

de Unmittelbar drohende Gefährdung:
Schwere Personenschäden oder Tod
en Risk of danger: Severe personal injury or material loss
fr Risque de danger: Blessures graves ou de perte de matériel
it Pericolo imminente: Danno fisico o materiale
es Riesgo de peligro: Daños severos tanto físicos como de materiales

WARNING

de Mögliche Gefährdung: Schwere Personenschäden oder Tod
en Possible dangers: Severe personal injuries or death
fr Dangers possibles: Blessures graves ou mortelle
it Possibile pericolo: danno fisico o mortale
es Posibles peligros: Daños físicos severos o muerte

CAUTION

de Unmittelbar drohende Gefährdung:
Personen oder Sachschäden
en Risk of danger: Personal injury or material loss
fr Risque de danger: Blessures ou de perte de matériel
it Pericolo imminente: Danno fisico o materiale
es Riesgo de peligro: Daños físicos o de materiales

de Element mit angegebenen Drehmoment anziehen.
en Fasteners must be tightened to a specific torque.
fr Les fixations doivent être serrées à un couple spécifique.
it I fissaggi devono essere stretti ad una coppia di serraggio specifica.
es Los cierres deben apretarse a un par de apriete determinado.

NOTE:

de Anweisung/Information für eine korrekte Reparatur
en Instruction/Information for a correct repair
fr Instruction/Information pour une réparation correcte
it Istruzioni/Informazioni per una corretta riparazione
es Instrucciones/Información para una correcta reparación

Sicherheitshinweise ♦ Safety Instructions ♦ Consignes de sécurité ♦ Informazioni di sicurezza Normas de seguridad

WARNING

- **Reparaturarbeiten an Geräten der Fahrzeugbremsanlage darf nur qualifiziertes Personal einer Fachwerkstatt durchführen.**
 - Leisten Sie den Vorgaben und Anweisungen des Fahrzeugherstellers unbedingt Folge.
 - Halten Sie Unfallverhütungsvorschriften des Betriebes sowie nationale Vorschriften ein.
 - Verwenden Sie ausschließlich von WABCO oder vom Fahrzeughersteller freigegebene Ersatzteile.
 - Beginnen Sie die Reparatur erst dann, wenn Sie alle Informationen, die für die Reparatur notwendig sind, gelesen und verstanden haben.
- Zusätzlich benötigte Dokumente: Prüfanweisung, Ersatzteilblatt, Allgemeine Reparatur- und Prüfhinweise (820 001 074 3) zu finden auf www.wabco-auto.com mittels Eingabe der Produktnummer des Gerätes bzw. Druckschriftennummer in INFORM.
- Prüfen Sie jedes reparierte Gerät - gemäß Prüfanweisung - an einer adäquaten Einrichtung auf Funktionstüchtigkeit und Dichtigkeit.

de

WARNING

- **Only qualified personnel of a specialist workshop are authorized to perform repair work on a vehicle's brake devices.**
- Absolutely follow specifications and instructions of vehicle manufacturer.
- Keep to company's relevant accident prevention regulations and national regulations.
- Use only spare parts released by WABCO or vehicle manufacturer.
- Always start repair work only when you have read and understood all information required for repair. Documents additionally needed: Test Instruction, Spare Parts List, General Repair and Test Hints (820 001 075 3) to be found on www.wabco-auto.com by entering product number of the device or the publication number in INFORM.
- Check each repaired equipment for functional efficiency and tightness on an adequate facility according to the test instruction.

en

WARNING

- **Uniquement le personnel qualifié d'un atelier agréé WABCO est autorisé à effectuer la réparation sur les systèmes de freinage d'un véhicule.**
- Respecter aussi les prescriptions et instructions du constructeur du véhicule.
- Veillez aux règlements de prévention des accidents indiqués par votre société et aux règlements nationaux.
- Employez seulement les pièces de rechange WABCO ou du constructeur du véhicule.
- Commencez toujours le travail de réparation seulement après avoir lu et compris toutes les informations indiquées pour la réparation. Documentation complémentaire nécessaire : Instruction d'essai, liste des pièces détachées, instructions de réparation et conseils d'essai 820 001 077 3 en tapant la référence du produit ou le numéro de la publication dans INFORM par internet : www.wabco-auto.com
- Examinez chaque appareil réparé pour s'assurer de l'efficacité fonctionnelle et l'étanchéité selon l'instruction d'essai.

fr

WARNING

- **Soltanto il personale qualificato delle officine specializzate sono autorizzate ad effettuare le riparazioni sui dispositivi di frenatura dei veicoli.**
- E' assolutamente necessario seguire le istruzioni e le specifiche del costruttore del veicolo.
- Attenersi alle norme nazionali e aziendali in merito alla prevenzione degli infortuni.
- Usare solo ricambi originali WABCO o del costruttore del veicolo.
- Effettuare la riparazione solamente dopo aver letto e capito tutte le informazioni richieste per la riparazione. Ulteriori informazioni necessarie: istruzioni di collaudo, catalogo dei ricambi, cenni generali sulla riparazione e test 820 001 078 3 possono essere trovati sul sito www.wabco-auto.com alla voce INFORM entrando per codice del dell'apparecchio o per numero della pubblicazione.
- Controllare la funzionalità e l'efficienza di ogni apparecchiatura riparata secondo le istruzioni riportate nel manuale di collaudo.

it

WARNING

- **Sólo el personal cualificado de un taller especializado está autorizado para realizar las tareas de reparación de aparatos de freno de vehículos.**
- Atenerse exactamente a las indicaciones e instrucciones del fabricante del vehículo.
- Siga las regulaciones y normas acerca de prevención de riesgos laborales de su empresa y de su país.
- Utilice piezas de repuesto suministradas por WABCO o el fabricante del vehículo.
- Comience la reparación sólo cuando haya leído y comprendido las instrucciones de reparación. Documentos adicionales necesarios: Instrucciones de comprobación, listas de despiece, consejos generales de comprobación y reparación (820 001 076 3), los cuales pueden encontrarse en www.wabco-auto.com, introduciendo la referencia del aparato o la referencia de la publicación en la aplicación INFORM.
- Compruebe la eficacia de funcionamiento y de ajuste de cada equipo reparado en unas instalaciones adecuadas según las instrucciones de comprobación.

es

This description should be used in order to assemble the service pressure sensor kit to the cover housing of the Volvo I-Shift System.

The description is related to gearbox installations with direct access to the top of the gearbox. In all other cases it might be necessary to strip the gearbox.

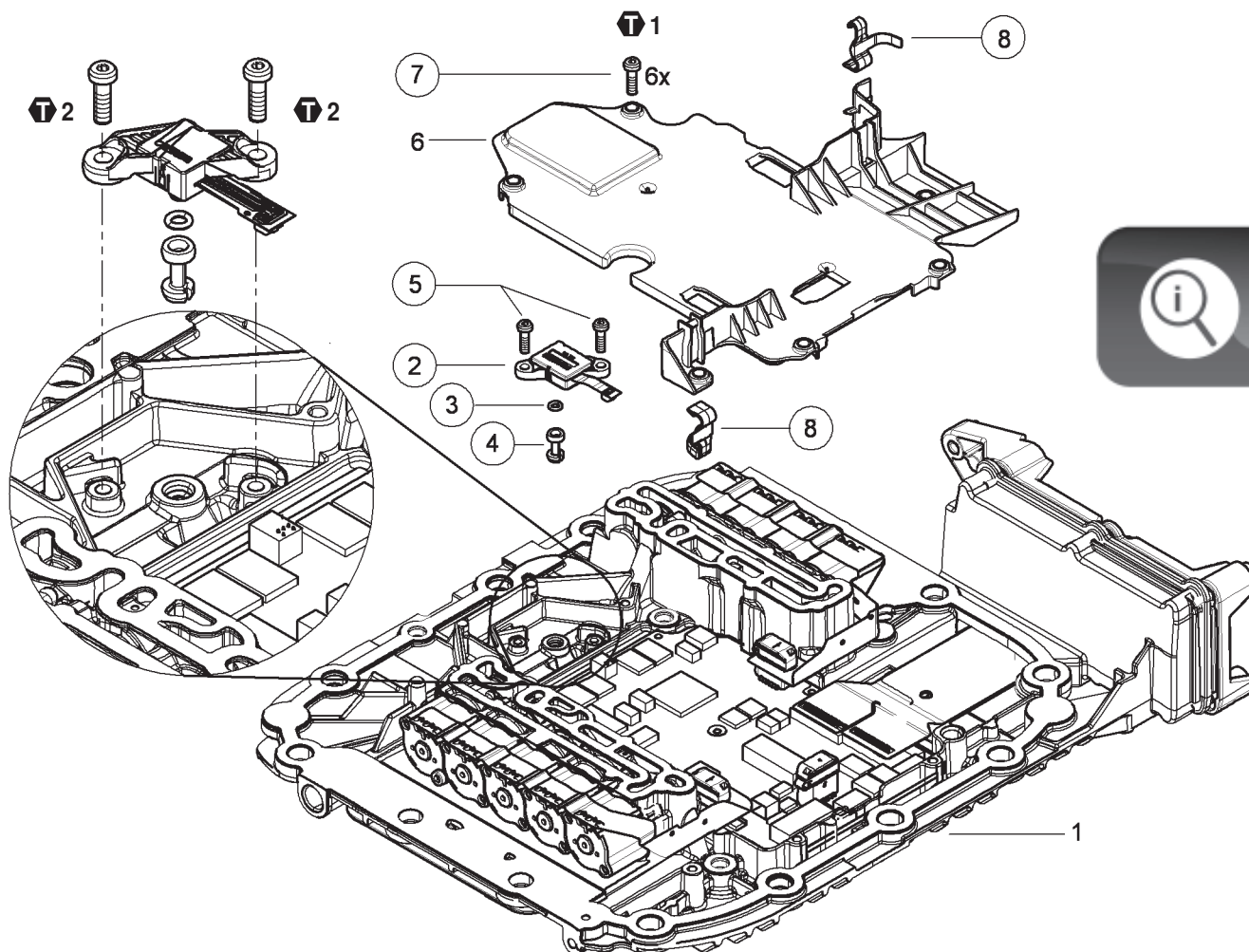

T1 M = 4 +1 Nm

T2 Fix pressure sensor with two self tapping bolts M 5x16 with a Torx socket spanner that screw head is flush with sensor plastic body. Check distance between screw head and plastic body with feeler gauge 0.1 mm to 0.2 mm. Turn screw right additional 120° to 180°.

Disassembling of Cover:

- Disconnect 20pol connectors from wiring harness to the control unit.
- Open cable tie at connector support at right gearbox side.
- Disconnect supply air tubes on the left and rear side of the control unit.
- Unscrew all 14 bolts M 12 from the flange.
- Unscrew all six screws M 8 from the upper side of the control unit.
- Lift cover from the rear side into front direction to a 60° to 80° position. This position gives access to the sensor cabling. Disconnect the plug from the cover. Take care that cabling doesn't get damaged (sketch1).
- Lift out cover and lay it upside down on a workbench.

○ = Les pièces sont dans la pochette
 ○ = Particolare contenuto nel corredo

○ = Diese Teile sind im Reparatursatz enthalten
 ○ = These parts are included in the repair kit
 ○ = Estas piezas están incluidas en el conj. de reparación

Repair Work on Cover:

○ = Les pièces sont dans la pochette
 ○ = Particolare contenuto nel corredo

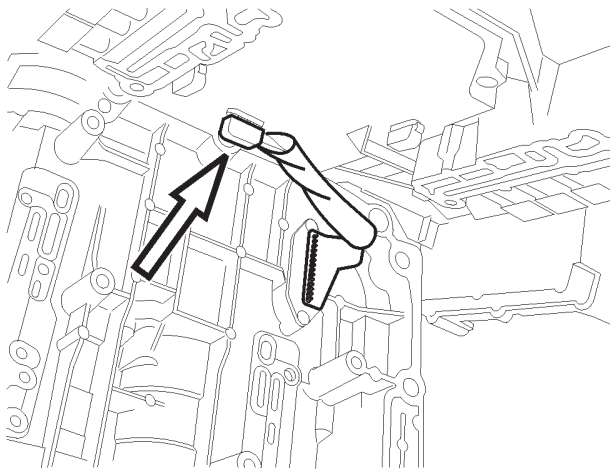

Sketch 1 view from the rear

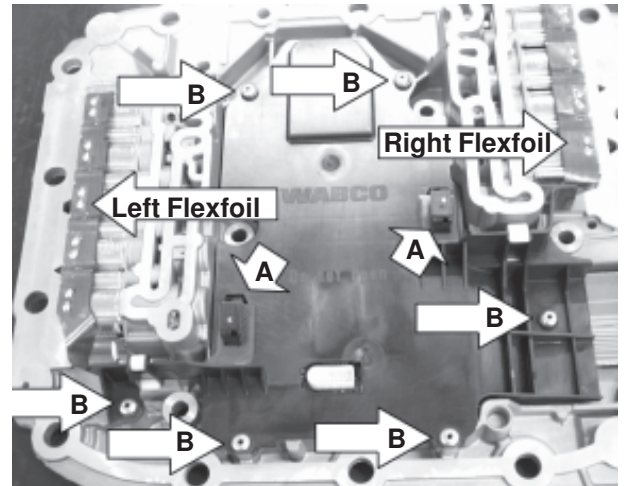

Picture 1

- Disconnect the both 12pol connectors (picture 1, arrows A) don't use sharp edged tools; don't place tool beneath flex foil.
- Remove all threaded rivets (6 pcs; picture 1; arrows B). Use a hexagon socket spanner 2.5mm. Turn spanner left. Insert hexagon socket spanner as deep as possible.

○ = Diese Teile sind im Reparaturatz enthalten
 ○ = These parts are included in the repair kit
 ○ = Estas piezas están incluidas en el conj. de reparación

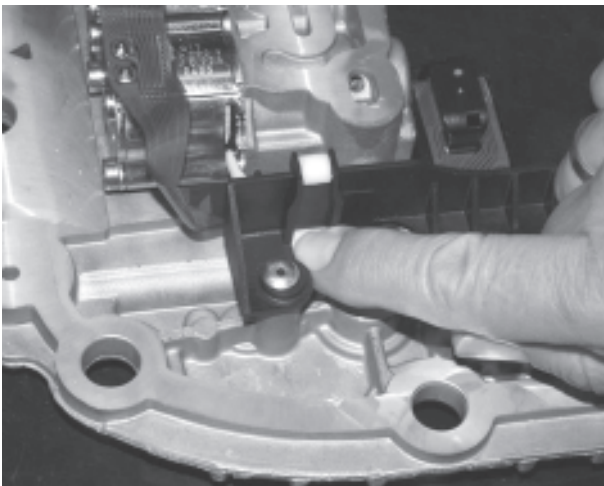

Picture 2

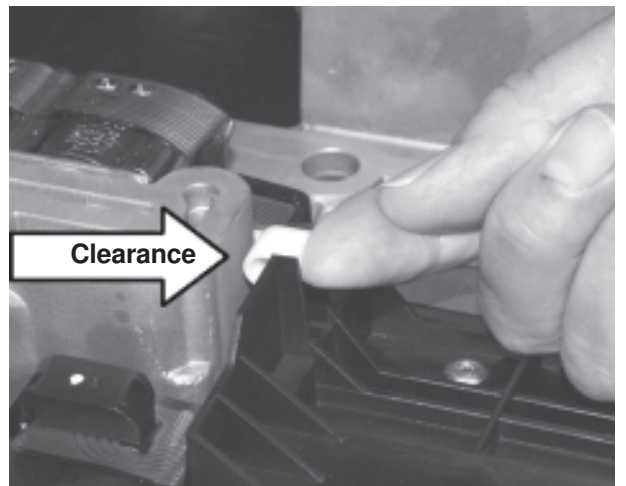

Picture 3

- Release the both white plastic clips (refer to picture 2 / 3), press clip left flex foil side down. Lift clip right flex foil side up.
- Left flex foil can be detached from the fixation pins of the black heat shield directly.
- Lift heat shield carefully for clearance from the aluminum body and remove right clip (refer to picture 2). Detach right flex foil from the fixation pins at the heat shield.
- Remove heat shield completely.
- Electronic printed circuit board is now free. Handle carefully. Avoid electrostatic discharges and mechanic impact.

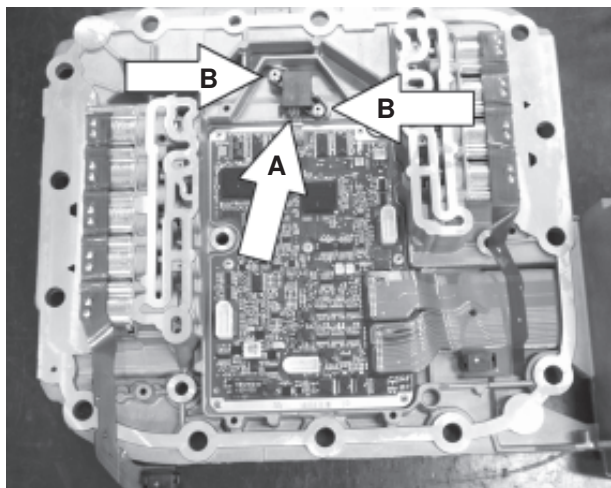

Picture 4

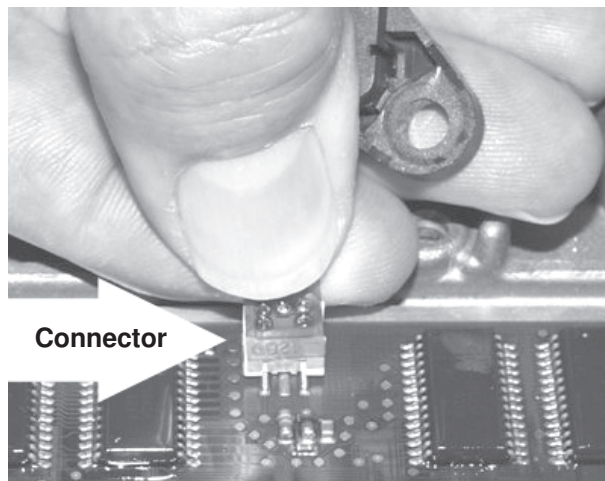

Picture 5

- Remove threaded rivets (2 pcs; picture 4; arrows B). Use a hexagon socket spanner 2.5mm. Turn spanner left. Insert hexagon socket spanner as deep as possible. Scrap the threaded rivets, they must not be used any more.
- Disassemble pressure sensor (picture 4, arrow A). Ensure that old O-ring is out of the connection bore.
- Disconnect pressure sensor connector carefully as shown in picture 5 by pulling at the flex foil.

Repair Procedure:

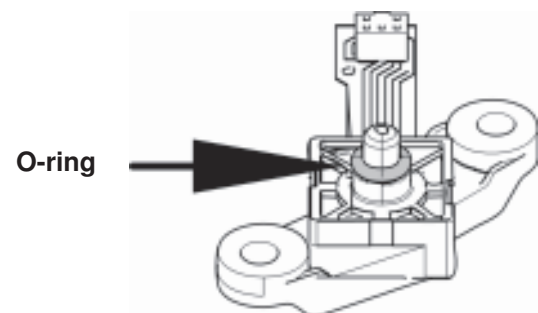

Sketch 2

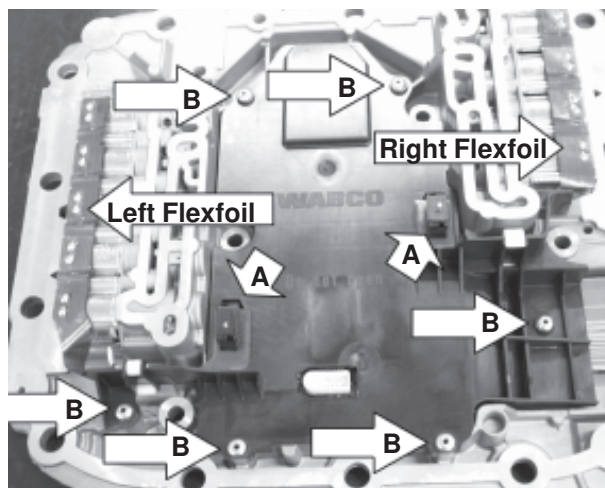

Picture 1

- Mount new O-ring on the spare part pressure sensor tap (refer to sketch 2).
- Mount spare part pressure sensor with O-ring to the connecting bore.
- Connect pressure sensor connector to the printed circuit board.
- Fix pressure sensor with two self tapping bolts M 5x16 with a Torx socket spanner that screw head is flush with sensor plastic body. Check distance between screw head and plastic body with feeler gauge 0.1 mm to 0.2 mm. Turn screw right additional 120° to 180°.
- Before lowering the heat shield fix the right flex foil on the heat shield pins and fasten flex foil with new clip.
- Bring the shield down. Fix five left flex foil at the heat shield pins and fasten with new clip.
- Assemble both 12pol connectors (picture 1, arrows A).
- Fasten heat shield with six self tapping bolts M 5x16 with a Torx socket spanner to a tightening torque 4 +1 Nm.
- Clean flange at cover and flange housing from old gasket.

○ = Les pièces sont dans la pochette
 ○ = Particolare contenuto nel corredo

○ = Diese Teile sind im Reparatursatz enthalten
 ○ = These parts are included in the repair kit
 ○ = Estas piezas están incluidas en el conj. de reparación

○ = Les pièces sont dans la pochette
 ○ = Particolare contenuto nel corredo

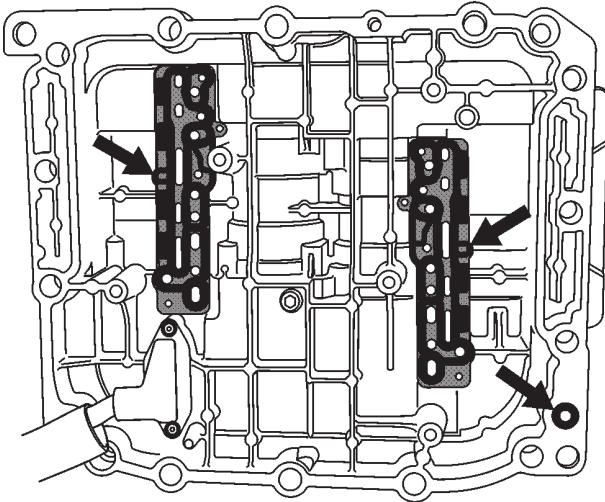

Sketch 3

- Check right position of O-ring for counter shaft brake supply and solenoid valve seals (sketch 3).
- Bring new flange gasket in position on flange housing.

Cover installation:

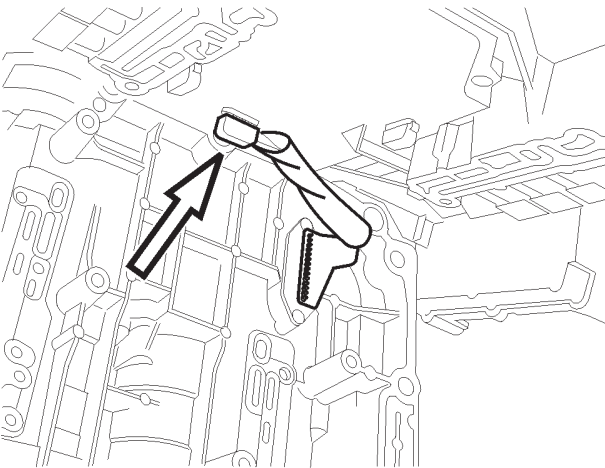

Sketch 1 view from the rear

- Bring cover in position like shown in sketch 1
- Connect sensor cabling. Take care that silicon protection tube on flex foil is in position and connector snaps in properly.
- Fold down cover to the normal position.
- Align flange gasket to hole pattern.
- Mount the six screws M 8 with tightening torque $23 \pm 3\text{Nm}$.
- Mount the 14 screws M 12 with tightening torque $75 \pm 10\text{ Nm}$.
- Connect 20pol connectors from wiring harness to control unit.
- Fasten wiring harness with cable tie to connector support.
- Connect air supply tubes on the left and rear side to the control unit.
- Pressurize system.
- Check for air leakage.
- Check I-Shift-System for proper function.

○ = Diese Teile sind im Reparatursatz enthalten
 ○ = These parts are included in the repair kit
 ○ = Estas piezas están incluidas en el conj. de reparación



de Nach der Reparatur kann ein Einlernvorgang erforderlich sein. Dieser Vorgang kann mit dem VOLVO Diagnose Tool oder der Wabcowürth Diagnose W.EASY (für Fahrzeug Baujahr 2005 bis 2013) durchgeführt werden.

en A learning procedure may be required following a repair. This procedure can be carried out with the VOLVO diagnostic tool or the W.EASY diagnosis from Wabcowürth (for vehicles with year of construction 2005 to 2013).

fr Après la réparation, il se peut qu'un apprentissage soit nécessaire. Cette procédure peut s'effectuer avec l'outil de diagnostic de VOLVO ou avec Diagnose W.EASY de Wabcowürth (pour les véhicules dont l'année de construction est comprise entre 2005 et 2013).

it Dopo la riparazione potrebbe essere necessario un processo di apprendimento. Questo processo può essere eseguito con lo strumento di diagnosi VOLVO o con lo strumento di diagnosi W.EASY Wabcowürth (per veicoli di modelli dal 2005 al 2013).

es Después de la reparación puede ser necesario efectuar un proceso de aprendizaje. Este proceso puede efectuarse con la herramienta de diagnosis VOLVO o con la herramienta de diagnosis W.EASY de Wabcowürth (para vehículos construidos entre 2005 y 2013).

○ = Les pièces sont dans la pochette
○ = Particolare contenuto nel corredo

○ = Diese Teile sind im Reparatursatz enthalten
○ = These parts are included in the repair kit
○ = Estas piezas están incluidas en el conj. de reparación